

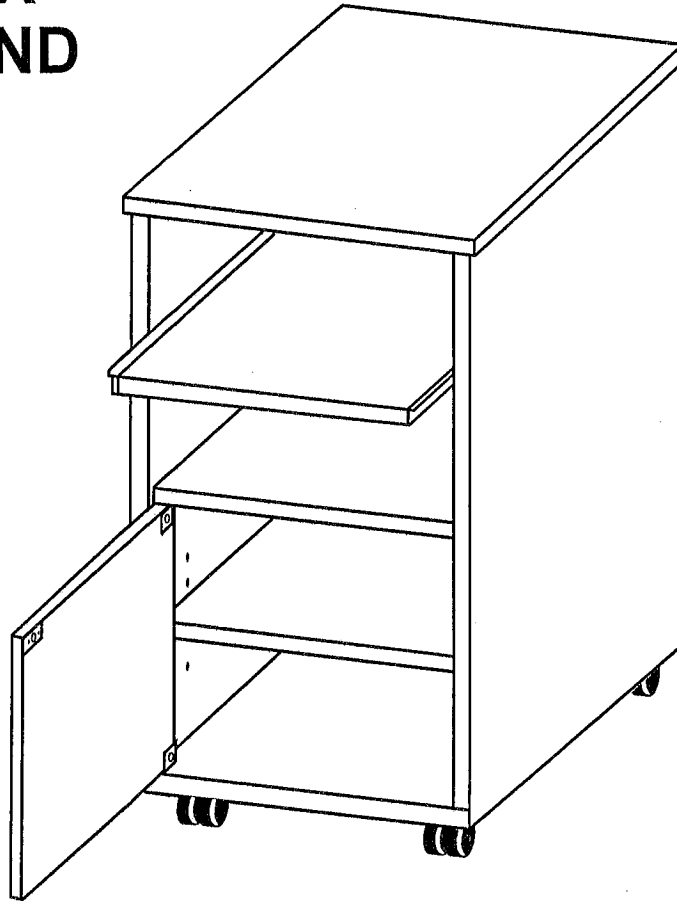

IRONWOOD

FXS

**FAX
STAND**



IMPORTANT!

Assembly may require the assistance of another person.

Before you begin assembly:

READ THE DIRECTIONS all the way through one time. This will speed up the process and help you understand the sequence of steps.

COUNT THE PARTS AND HARDWARE before assembly. This ensures you have received all necessary parts before you begin.

TOOLS: You may need a Phillips head screwdriver, a medium slotted screwdriver or a plastic mallet. To protect your new furniture from damage during assembly, it is recommended to work on a carpeted surface.

In the event any parts are missing from this package, send your name, address, telephone number, and a description of the missing part(s) to: PARTS, Box 1420, Missoula, MT 59806 or call: 1-800-769-5693 or FAX 1-800-445-5281.

CAUTION: On assemblies requiring glue, make sure the unit is assembled correctly before gluing. Once this unit is assembled with glue, the manufacturer will not be responsible for damaged parts. Keep a damp cloth or sponge handy to wipe off excess glue.

To care for this furniture, simply wipe with a cloth dampened with glass cleaner containing ammonia-D.

HARDWARE

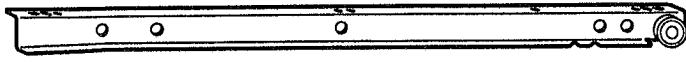

S4

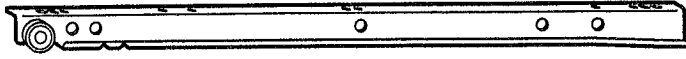

S3

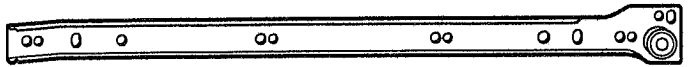

S2

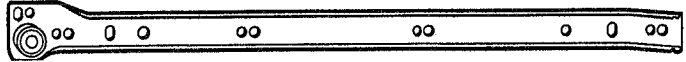

S1

Shelf Slide	490260	2 pr.
-------------	--------	-------

Slide Channel	490260	2 pr.
---------------	--------	-------

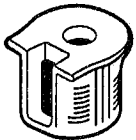

H1	Rafix Cam	909909	4 ea.
----	-----------	--------	-------

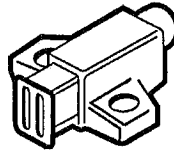

H2	Touch Latch	401025	1 ea.
----	-------------	--------	-------



H4	Rafix Bolt	909925	18 ea.
----	------------	--------	--------



H3	#6x5/8" Panhead Screw	901216	8 ea.
----	--------------------------	--------	-------



H6	Varianta Screw	988060	6 ea.
----	----------------	--------	-------

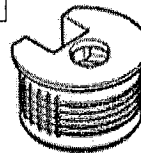

H5	Flush Rafix Cam	909911	14 ea.
----	--------------------	--------	--------



H8	#10x5/8 Panhead Screw	901220	16 ea.
----	--------------------------	--------	--------

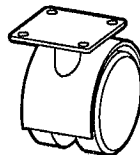

H7	Plate Caster	402050	4 ea.
----	--------------	--------	-------

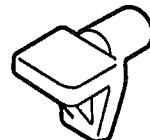

H9	Shelf Pin	297210	4 ea.
----	-----------	--------	-------

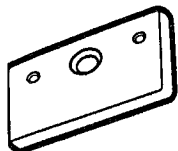

H11	Striker Plate	401100	1 ea.
-----	---------------	--------	-------



H12	#6x1/2 Flathead Screw	901118	1 ea.
-----	--------------------------	--------	-------



Hinge Insert

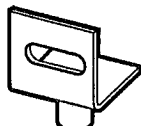

Hinge



#6-3/8" Panhead

Pin Hinge Set		400265	2 ea.
---------------	--	--------	-------

#2

Attach a Touch Latch (H2) to the underside of the Fixed Shelf (G) using two #6x5/8" Panhead Screws (H3) in the pre-drilled holes as shown.

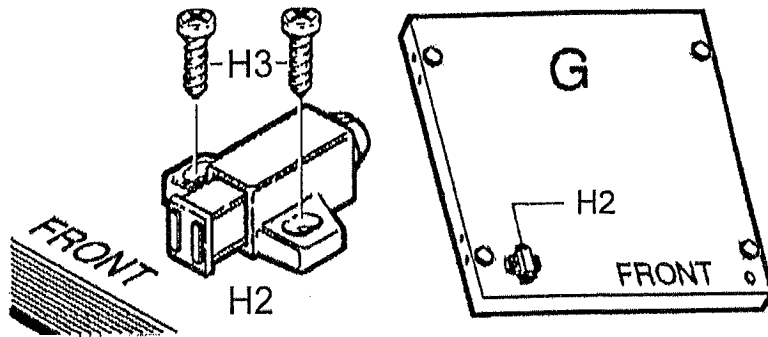

#3

Place the Top Panel (C) on a clean, carpeted surface or foam padding with the pre-drilled holes facing up. Screw four Rafix Bolts (H4) into the Top Panel as shown.

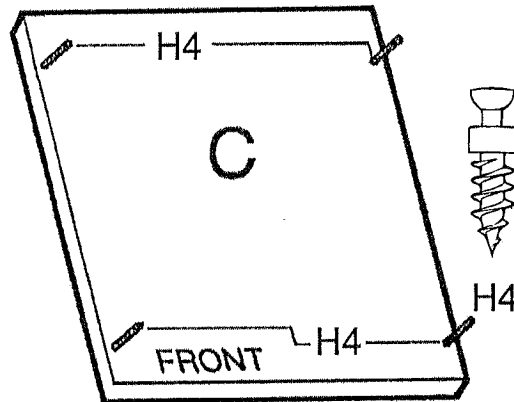

#4

Place the Left Side Panel (A) and the Right Side Panel (B) on a clean, carpeted surface or foam padding with the pre-drilled holes facing up. Insert 4 Rafix Flush Cams (H5) into the Left Side Panel and the Right Side Panel with the arrows of the cams facing out.

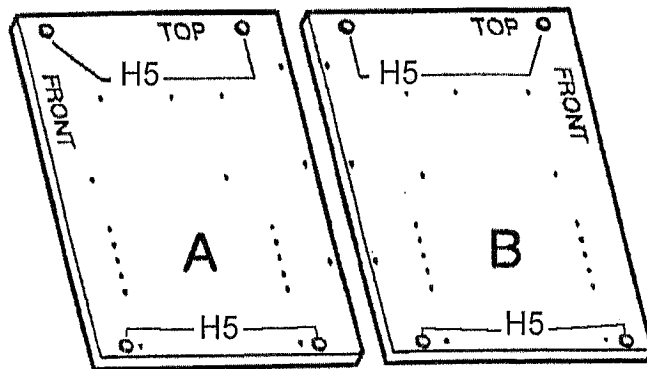

#5

Screw seven Rafix Bolts (H4) into the Left Side Panel (A) where indicated.



H4

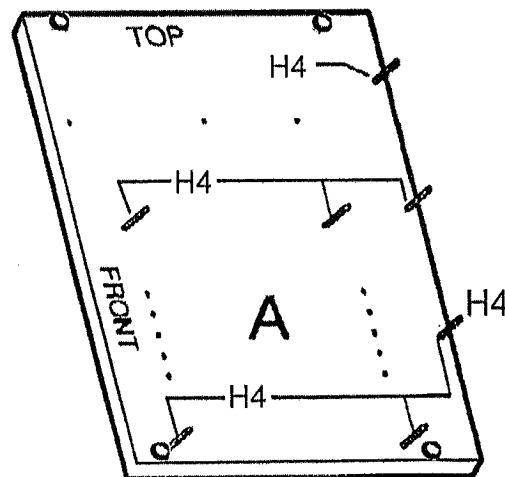

#9

Screw in 4 Rafix bolts into the Bottom Panel (E) to allow sides to connect.

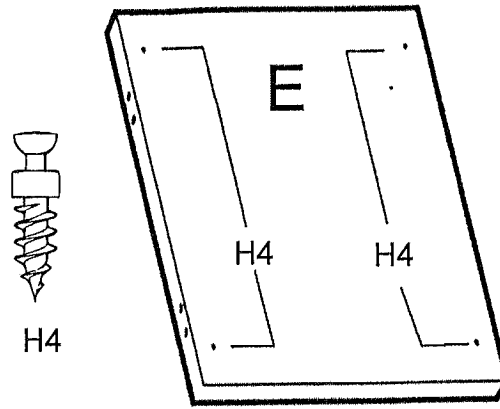

#10

Insert six Flush Rafix Cams (H5) into the Back Panel (D)

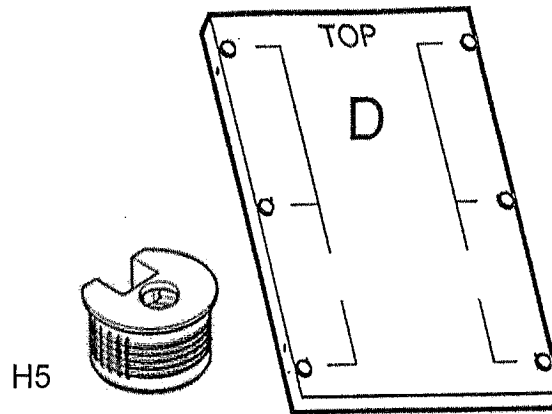

#11

Position the cams on the Back Panel (D) onto the bolts and dowels of the Left Side Panel (A) as shown. Turn to secure.

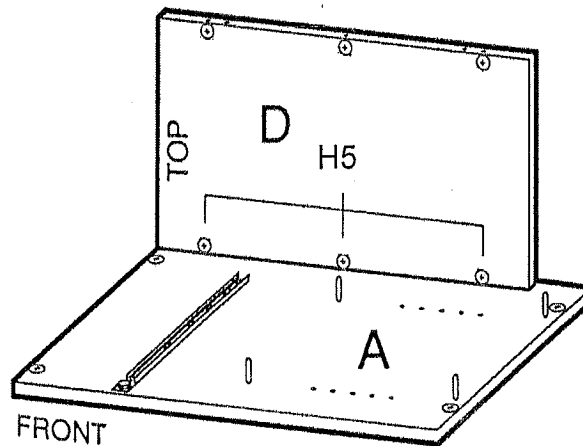

#12

Position the cams of the Fixed Shelf (G) with the front edge as shown onto the Left Side Panel (A). Turn the cams (H1) to secure.

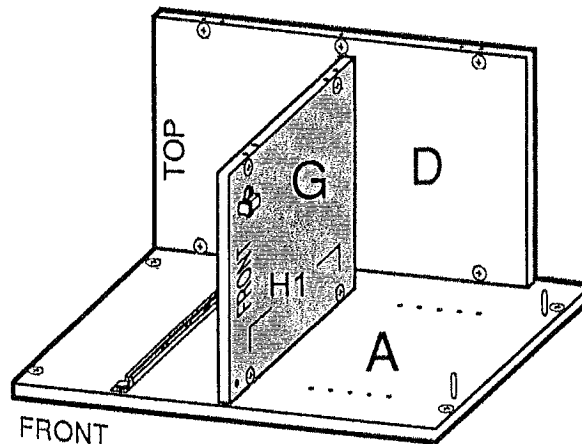

#15

Turn the unit upright. Position the Top Panel (C) onto the Left Side Panel (A) and the Right Side Panel (B) with the front edge as shown. Turn the cams (H5) to secure.

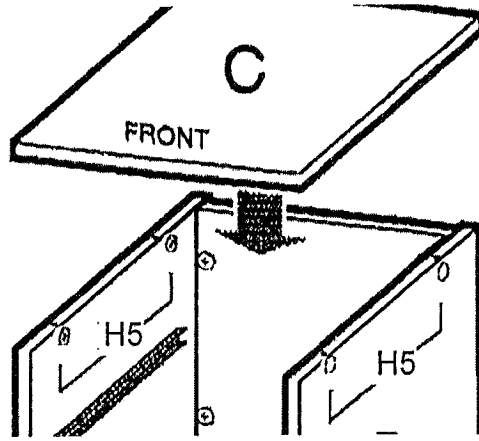

#16

Determine the height for the placement of the Adjustable Shelf (J). Insert Shelf Supports (H9) into the pre-drilled holes of the Left Side Panel (A) and the Right Side Panel (B) as shown.

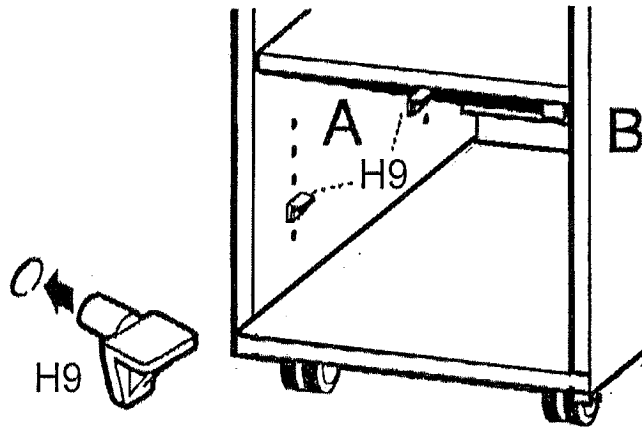

#17

Place the Adjustable Shelf (J) onto the Shelf Supports (H9) with the finished edge forward as shown.

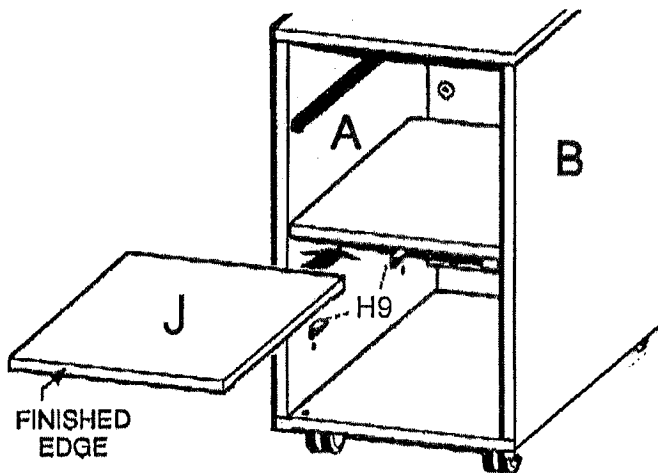

#18

Place the Sliding Shelf (F) with pre-drilled holes facing up as shown. Attach left and right Shelf Slides (S3 & S4) using the #6x5/8" Panhead Screws (H3) as shown.

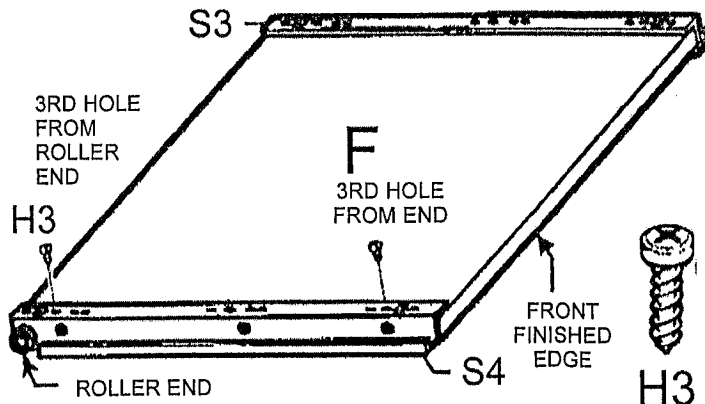

#23

Insert a Pin Hinge (H10) into the Cam Insert (H13) of the Bottom Panel (E) as shown.

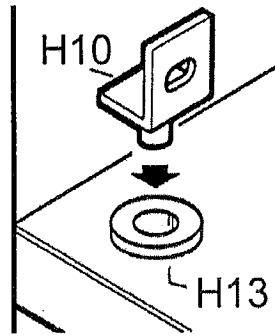

#24

Place the upper Pin Hinge into the upper Cam Insert and rotate the Door (I) into place as shown.

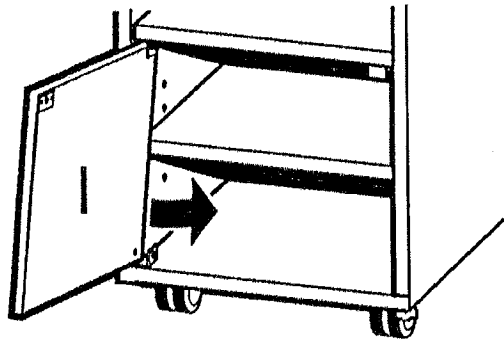

#25

Install a #6x3/8" Panhead Screw (H14) through the center of the slotted hole to attach the lower Pin Hinge (H10) to the Door (I) as shown.

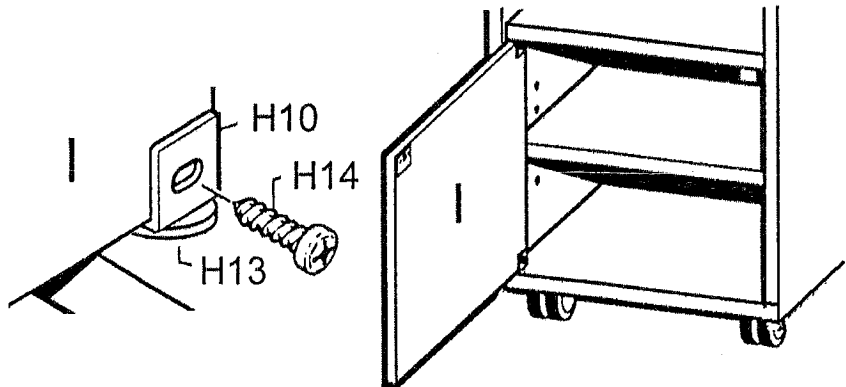

#26

Adjust the Hinge Inserts (H13) to obtain equal spacing around the Door.

Note: Loosen Panhead Screws, reposition Pin Hinges and retighten screws if further adjustment is necessary.

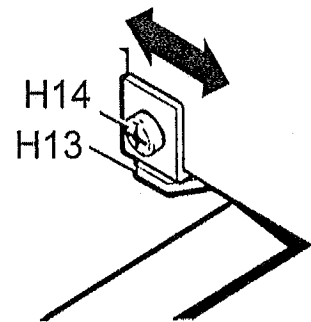

#27

If necessary, adjust the Touch Latch (H2) so that the Door opens and closes easily. Loosen the two Panhead Screws (H3), reposition the Touch Latch and retighten when adjusted.

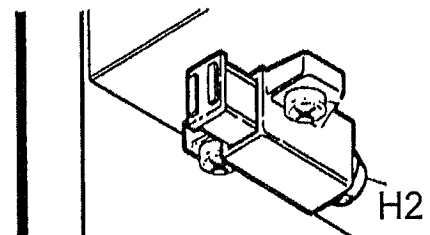

Your FAX Stand is now assembled and ready for use.