

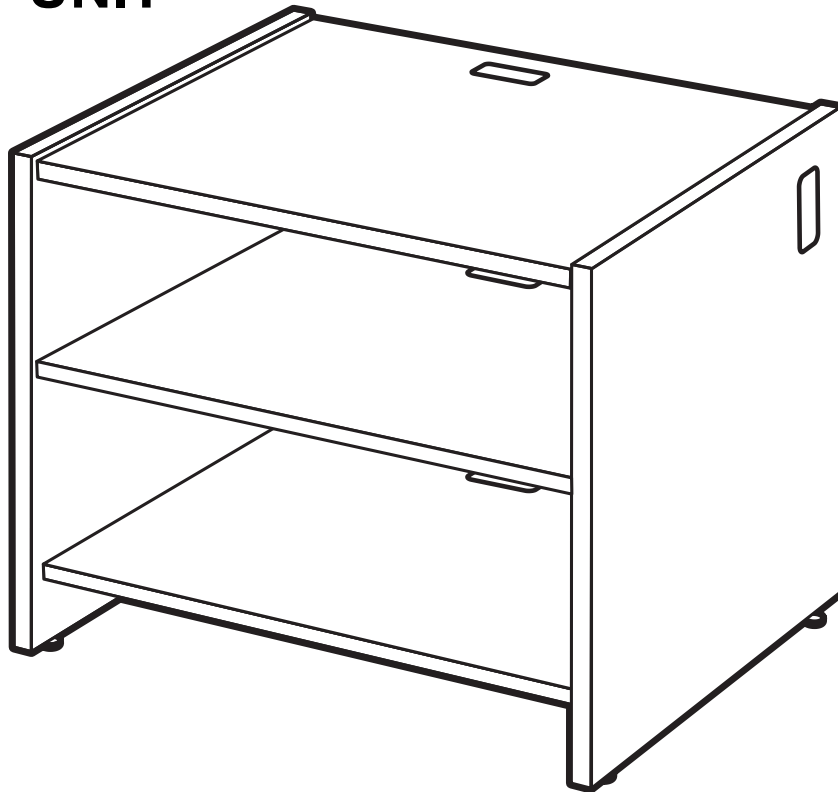

BY  **IRONWOOD**

CDAS CDAS39

SHELF UNIT



IMPORTANT!

Assembly may require the assistance of another person.

Before you begin assembly:

READ THE DIRECTIONS all the way through one time. This will speed up the process and help you understand the sequence of steps.

COUNT THE PARTS AND HARDWARE before assembly. This ensures you have received all necessary parts before you begin.

TOOLS: You may need a Phillips head screwdriver, a medium slotted screwdriver or a plastic mallet. To protect your new furniture from damage during assembly, it is recommended to work on a carpeted surface.

In the event any parts are missing from this package, send your name, address, telephone number, and a description of the missing part(s) to: **PARTS, Box 1420, Missoula, MT 59806** or call: **1-800-769-5693** or FAX **1-800-445-5281**.

CAUTION: On assemblies requiring glue, make sure the unit is assembled correctly before gluing. Once this unit is assembled with glue, the manufacturer will not be responsible for damaged parts. Keep a damp cloth or sponge handy to wipe off excess glue.

To care for this furniture, simply wipe with a cloth dampened with glass cleaner containing ammonia-D.

PARTS DIAGRAM

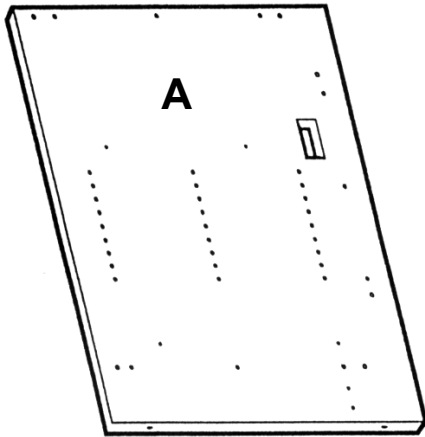

Left Side - CDAS	01010141	1 ea.
Left Side - CDAS39	01010241	1 ea.

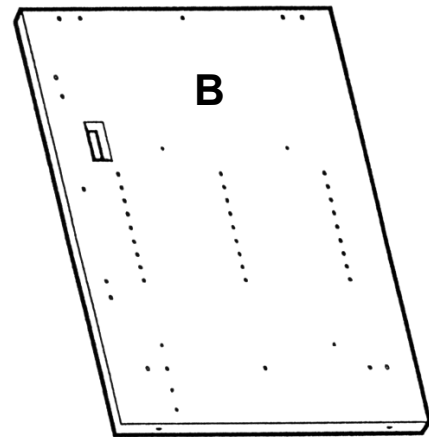

Right Side - CDAS	01010141	1 ea.
Right Side - CDAS39	01010241	1 ea.

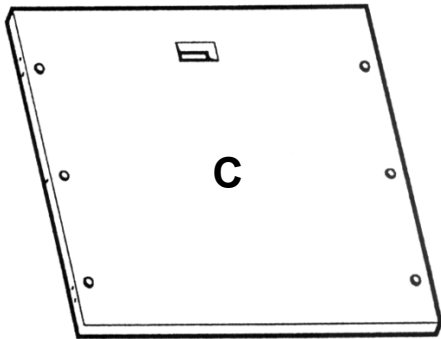

Top	01010101	1 ea.
-----	----------	-------

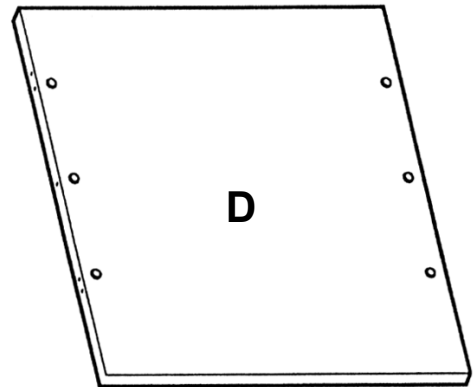

Back - CDAS	01010152	1 ea.
Back - CDAS39	01010252	1 ea.

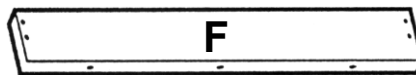

Toeboard	01010172	1 ea.
----------	----------	-------

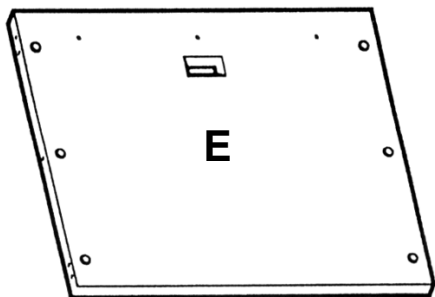

Bottom	01010111	1 ea.
--------	----------	-------

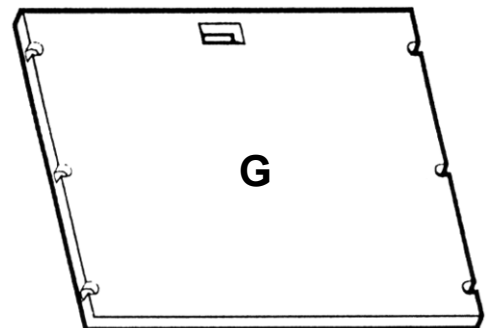

Adjustable Shelf	01010124	1 ea.
------------------	----------	-------

HARDWARE



H1	Leveler Insert	274650	4 ea.
----	----------------	--------	-------

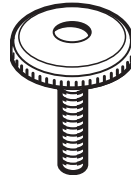

H2	Leveler	300870	4 ea.
----	---------	--------	-------



H3	Minifix Bolt	909834	18 ea.
----	--------------	--------	--------



H4	Dowel	195000	12 ea.
----	-------	--------	--------



H5	Minifix Cam	909810	18 ea.
----	-------------	--------	--------

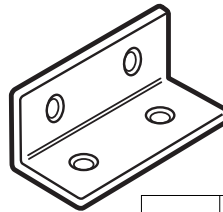

H6	Angle Bracket	401170	2 ea.
----	---------------	--------	-------



H7	Varianta Screw	988060	8 ea.
----	----------------	--------	-------



H8	Confirmat Screw	950100	3 ea.
----	-----------------	--------	-------



H9	Rafix Cam	909910	6 ea.
----	-----------	--------	-------



H10	Rafix Bolt	909923	6 ea.
-----	------------	--------	-------

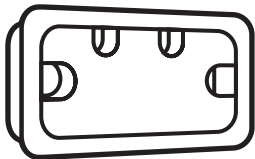

H11	Grommet	286580	5 ea.
-----	---------	--------	-------

Hardware for Connecting to Another Unit



H12	Connector Sleeve	950200	4 ea.
-----	------------------	--------	-------



H13	Connector Screw	901350	4 ea.
-----	-----------------	--------	-------

Using the Minifix System:

Insert the Minifix Cams into the appropriate holes with the arrow facing outwards as shown.

When screwing post into hole, **Do Not** over tighten. Screw post down until bottom face of post flange just touches board surface.

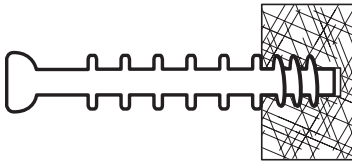

Using the #2 Phillips screwdriver, rotate the Cam Devices a half turn clockwise until snug.

To disassemble, turn the Cam Devices counter-clockwise and remove panels.

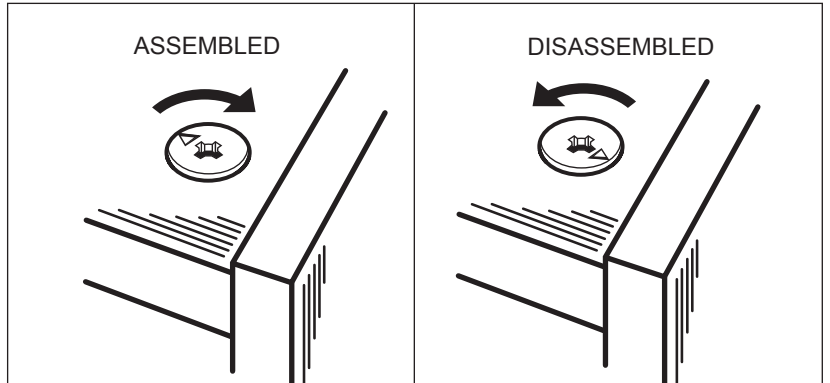
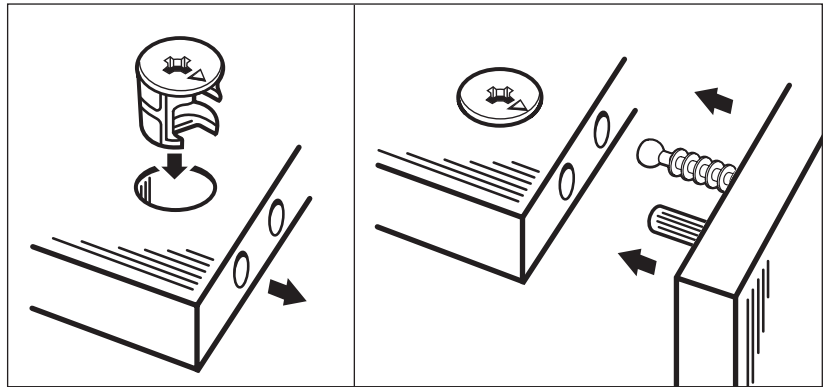

Using the Rafix System:

Insert the Rafix Cams into the appropriate holes. The flat edge of the cam should be facing the edge of the panel.

Slide Rafix Cams of the panel to be attached onto the corresponding posts.

When screwing post into hole, **Do Not** over tighten. Screw post down until bottom face of post flange just touches board surface.

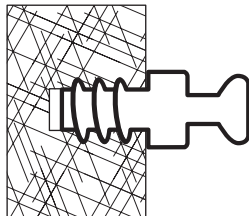

Using a #3 Phillips screwdriver, turn the rotating portion of the Rafix Cam a 1/2 turn clockwise to secure. **IMPORTANT!** Do not exceed 1/2 turn when tightening cams. Turn 1/2 turn counterclockwise to disassemble and remove panel.

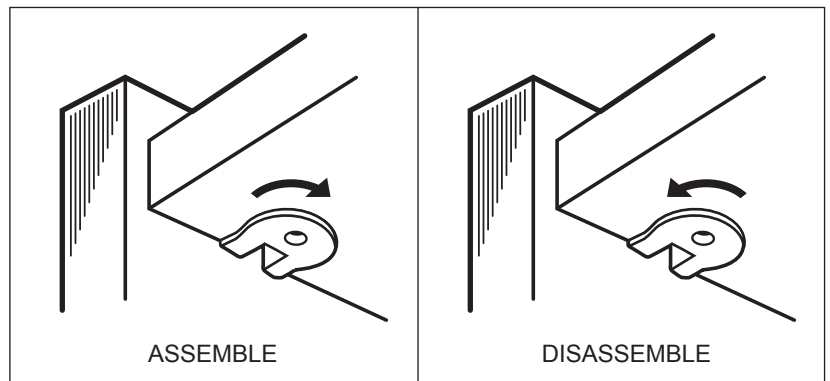
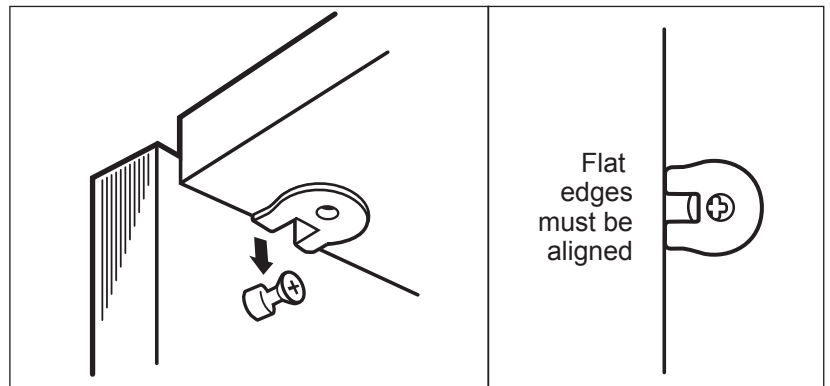

#1

Place the Left Side (A) and Right Side (B) on a clean carpeted surface with the pre-drilled holes facing up. Insert the Leveler Inserts (H1) into the holes in the bottom edges of each Side. Using a plastic mallet, tap until flush with the surface. Screw the Levelers (H2) into the Leveler Inserts.

Adjust Levelers when the assembled unit is in place.

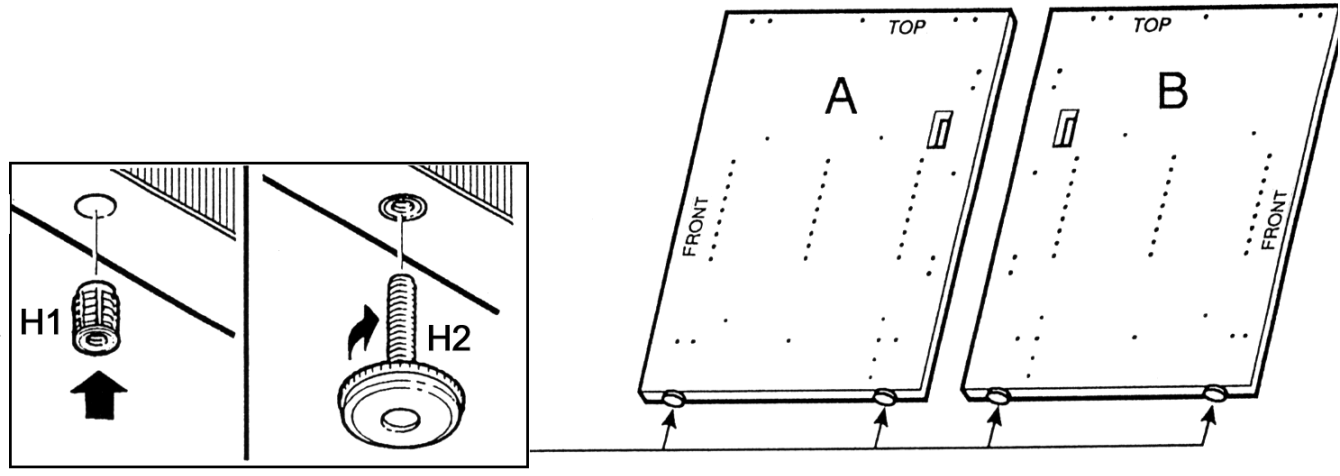

#2

Screw nine Minifix Bolts (H3) and insert six Dowels (H4) into the Left Side (A) and Right Side (B) where indicated.

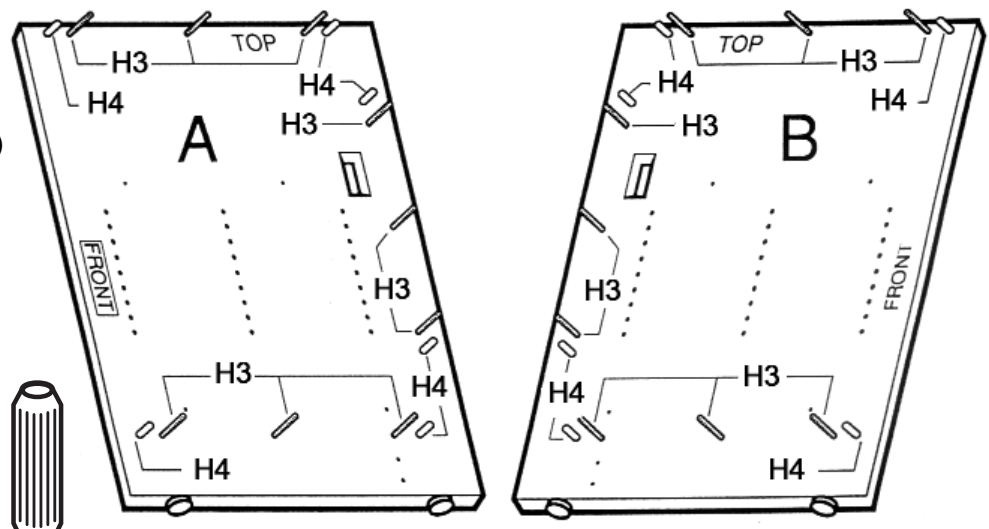
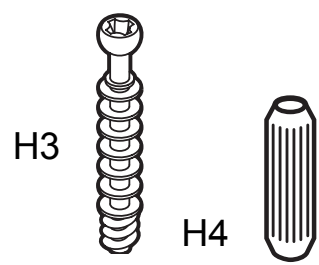

#3

Insert six Minifix Cams (H5) into the Top (C) and Back (D) with the arrows of the cams facing out.

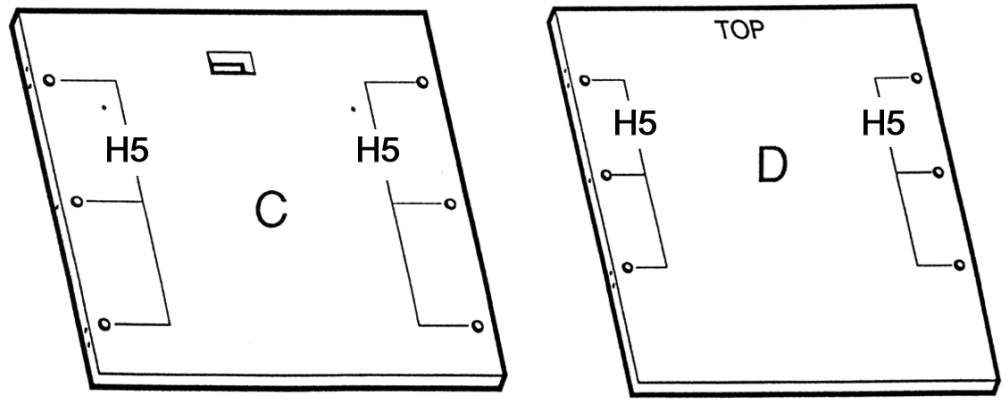

#4

Secure an Angle Bracket (H6) to each end of the Toeboard (F) using the Varianta Screws (H7).

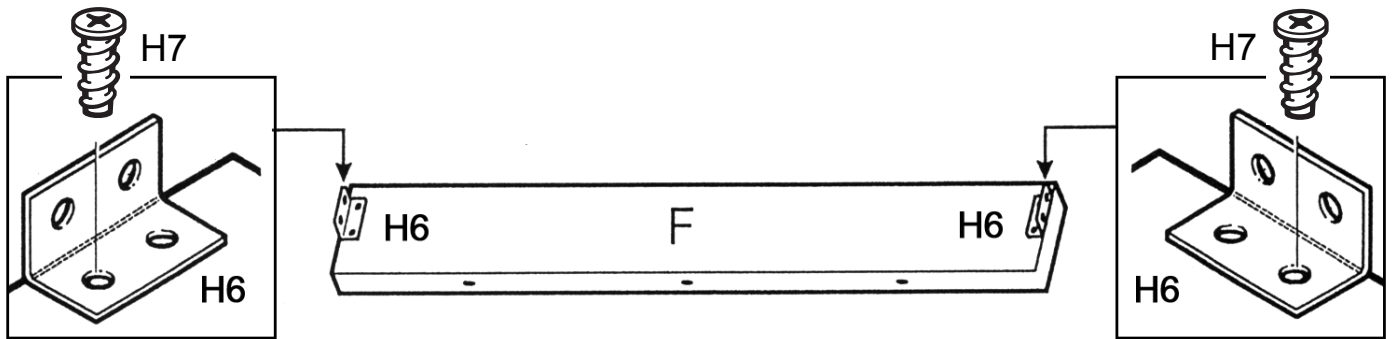
**#5**

Insert six Minifix Cams (H5) into the Bottom (E) with the arrows of the cams facing out.

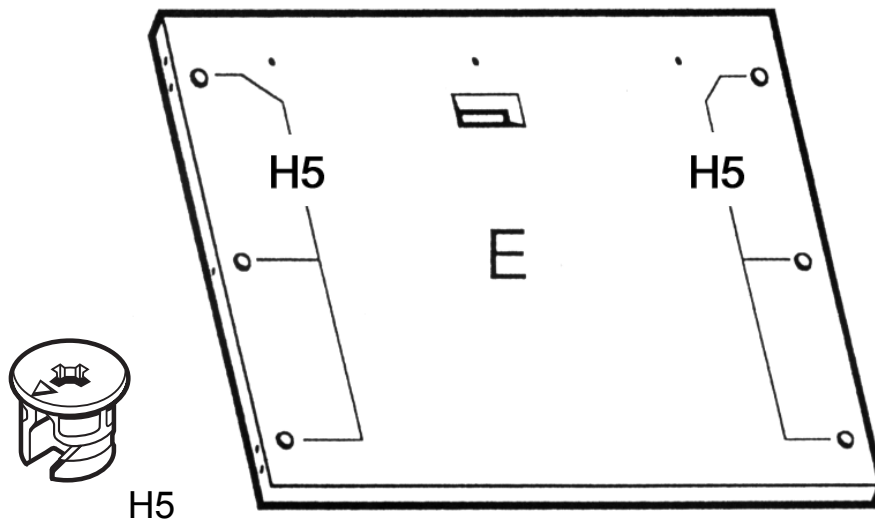
**#6**

Attach the Toeboard (F) to the Bottom (E) using three Confirmat Screws (H8) through the pre-drilled holes as shown.

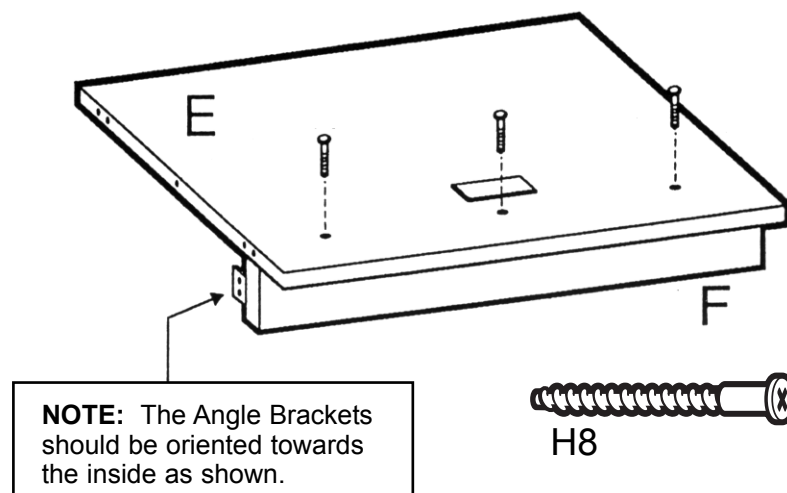

#7

Place the Left Side (A) as shown. Position the Top (C) onto the Left Side. Turn the cams (H5) clockwise to secure.

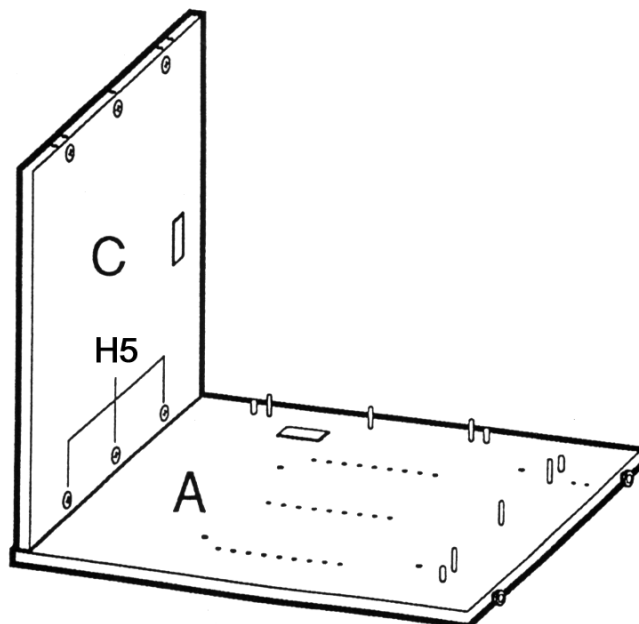

#8

Position the Back (D) onto the Left Side (A) and turn cams (H5) clockwise to secure.

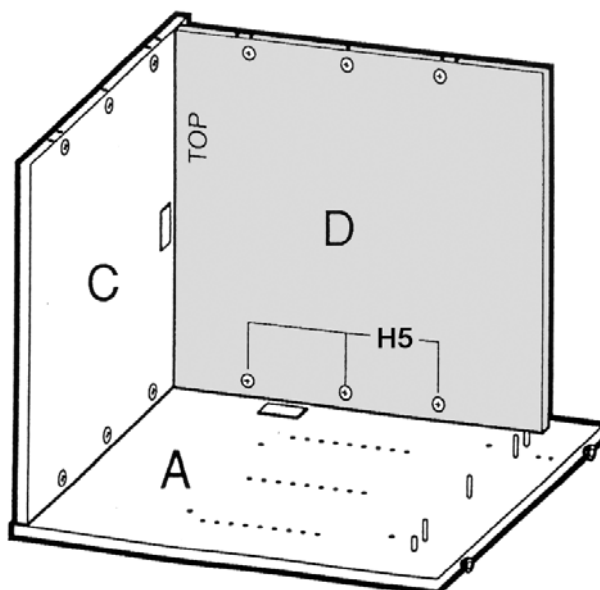

#9

Position the Bottom Shelf (E) and Toeboard (F) assembly onto the Left Side (A) and turn cams (H5) to secure.

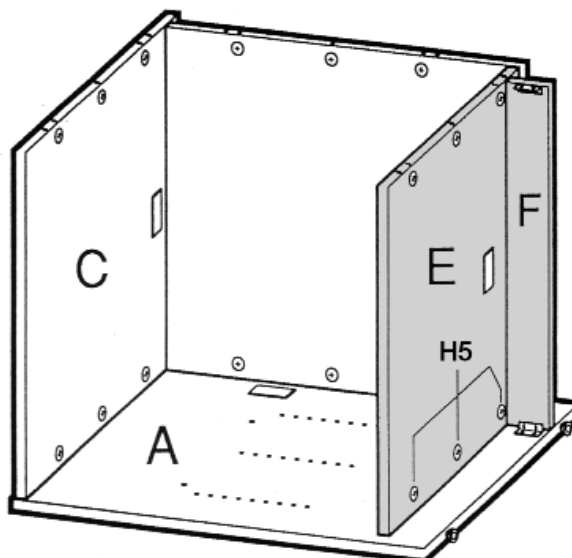

#10

Position the bolts and dowels of the Right Side (B) onto the unit and turn cams (H5) clockwise to lock in place.

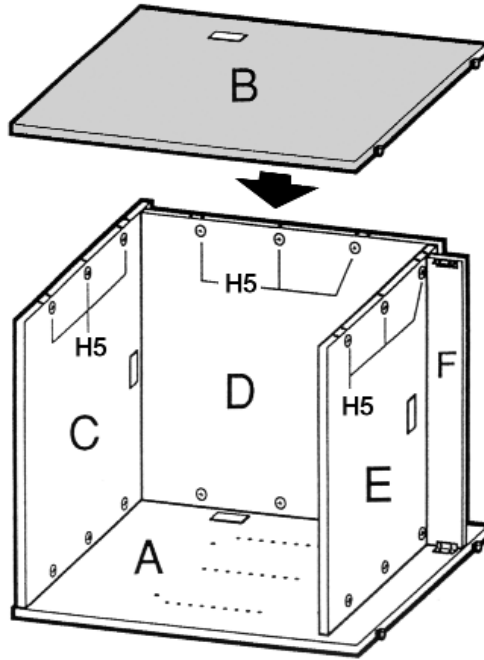

#11

Secure the Angle Brackets (H6) of the Toeboard (F) to the Left Side (A) and Right Side (B) using Varianta Screws (H7).

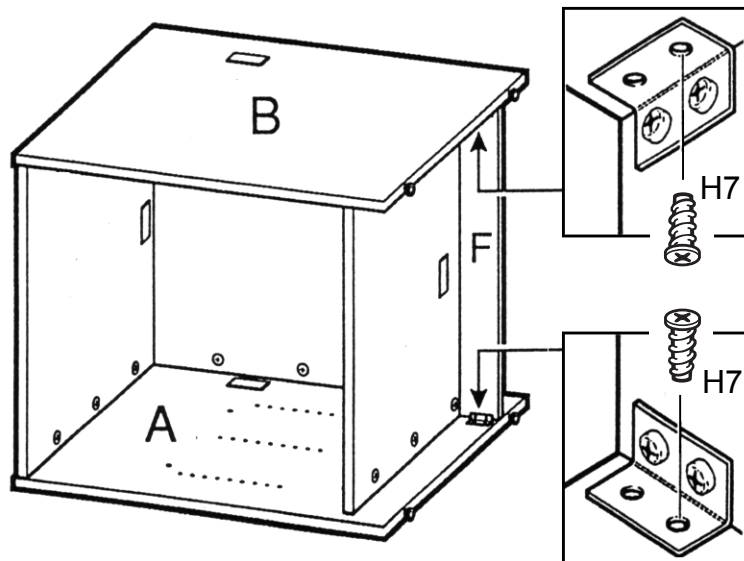

#12

Insert six Rafix Cams (H9) into the Adjustable Shelf (G) with the flat edge facing outwards and tap until fully seated in place as shown.

Note: The edge of the Rafix Cam must be aligned with the shelf edge. Rafix Cams cannot be repositioned if installed incorrectly.

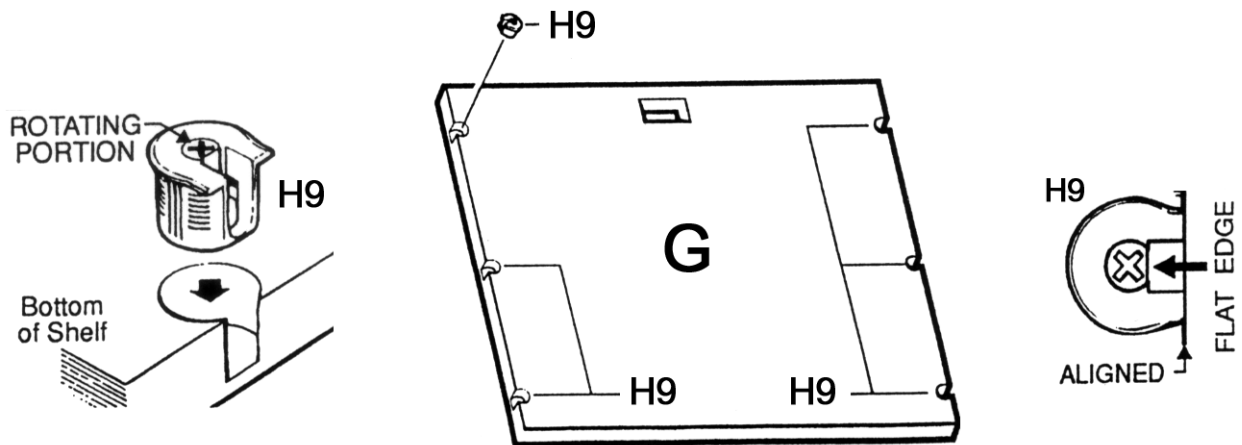

#13

With the assistance of another person, turn the unit upright. Screw three Rafix Bolts (H10) into pre-drilled holes of each Side (A & B) at a selected height. Position the Adjustable Shelf (G) onto the posts as shown. Using a #3 Phillips screwdriver, turn the rotating portions of the cams $\frac{1}{4}$ -turn clockwise to secure.

Note: Do not exceed $\frac{1}{4}$ -turn when tightening cams!

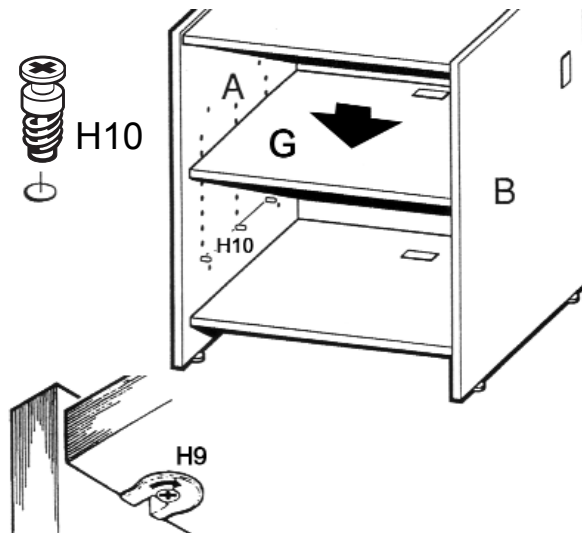

#14

Insert Grommet (H11) into the Left Side (A), Right Side (B), Top (C), Bottom (E), and the Adjustable Shelf (G).

Your Glacier Circulation Shelved Storage Unit is now fully assembled and ready for use.

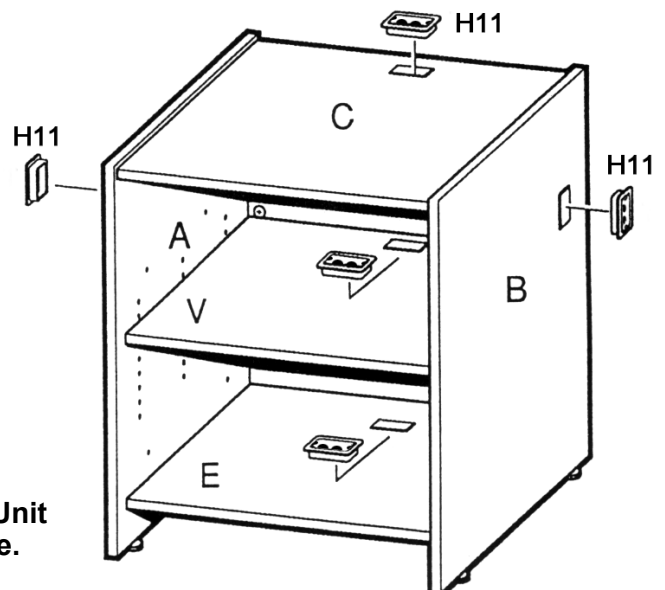

CONNECTING TO OTHER CIRCULATION DESK UNITS

Remove Grommets (H11) from the panels to be connected.

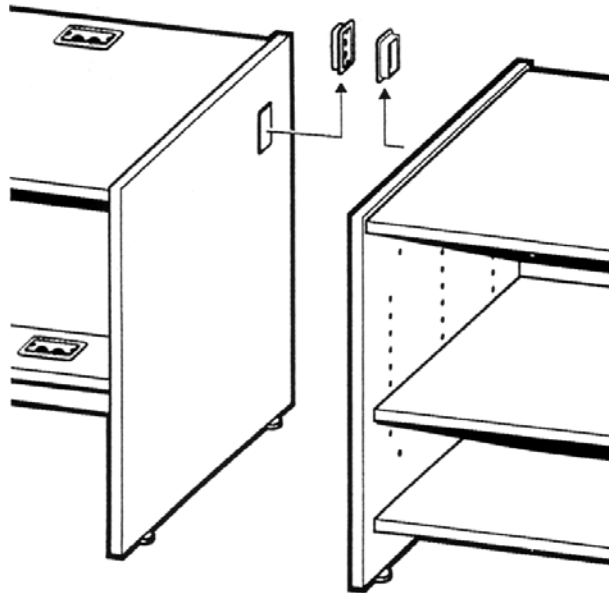

Using a 13/64" bit, drill through the four pilot holes on the inside of each side panel.

Align the side panels of the units to be connected. Tap four Connector Sleeves (H12) through the holes in one side panel and into the holes of the unit to be connected. From the other side, secure the units together using four Connector Screws (H13).

