



BY  **IRONWOOD**

CDCU

CDCU29

CDCU39

CORNER UNIT

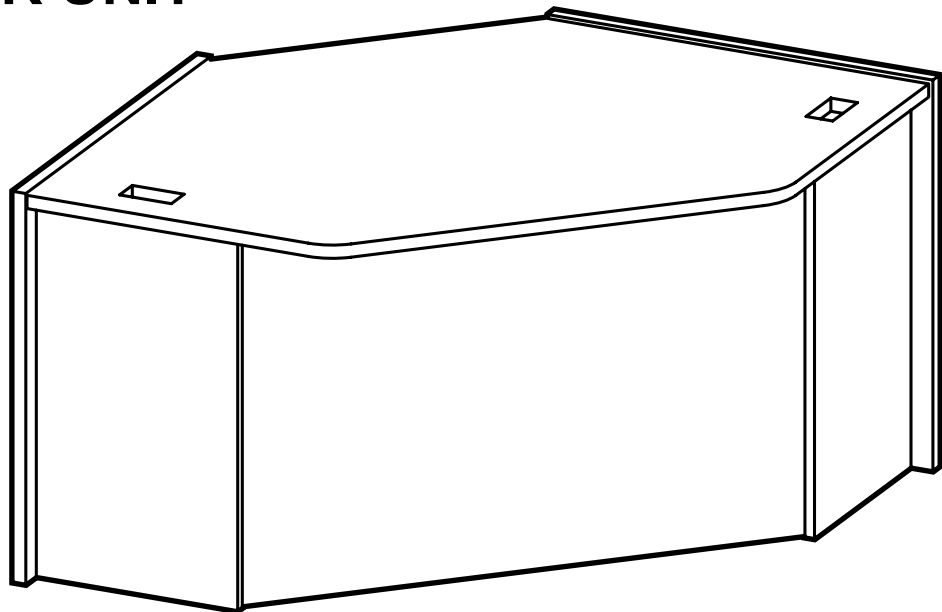

IMPORTANT!

Assembly may require the assistance of another person.

Before you begin assembly:

READ THE DIRECTIONS all the way through one time. This will speed up the process and help you understand the sequence of steps.

COUNT THE PARTS AND HARDWARE before assembly. This ensures you have received all necessary parts before you begin.

TOOLS: You may need a Phillips head screwdriver, a medium slotted screwdriver or a plastic mallet. To protect your new furniture from damage during assembly, it is recommended to work on a carpeted surface.

In the event any parts are missing from this package, send your name, address, telephone number, and a description of the missing part(s) to: **PARTS, Box 1420, Missoula, MT 59806** or call: **1-800-769-5693** or FAX **1-800-445-5281**.

CAUTION: On assemblies requiring glue, make sure the unit is assembled correctly before gluing. Once this unit is assembled with glue, the manufacturer will not be responsible for damaged parts. Keep a damp cloth or sponge handy to wipe off excess glue.

To care for this furniture, simply wipe with a cloth dampened with glass cleaner containing ammonia-D.

PARTS DIAGRAM

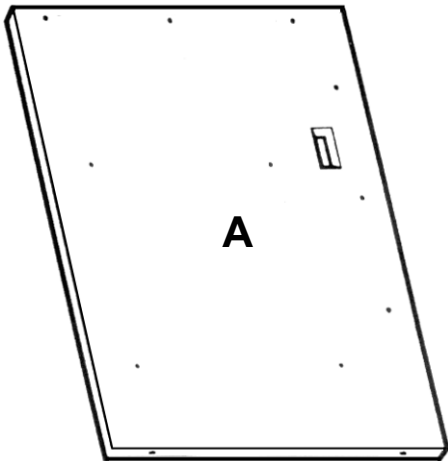

Left Side - CDCU	01011041	1 ea.
Left Side - CDCU29	01013141	1 ea.
Left Side - CDCU39	01011141	1 ea.

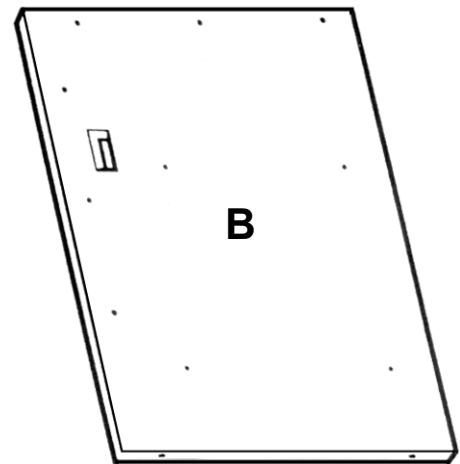

Right Side - CDCU	01011041	1 ea.
Right Side - CDCU29	01013141	1 ea.
Right Side - CDCU39	01011141	1 ea.

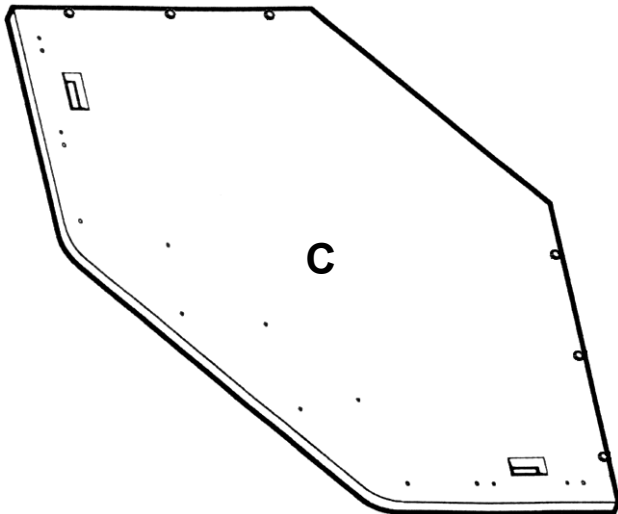

Top	01011001	1 ea.
-----	----------	-------

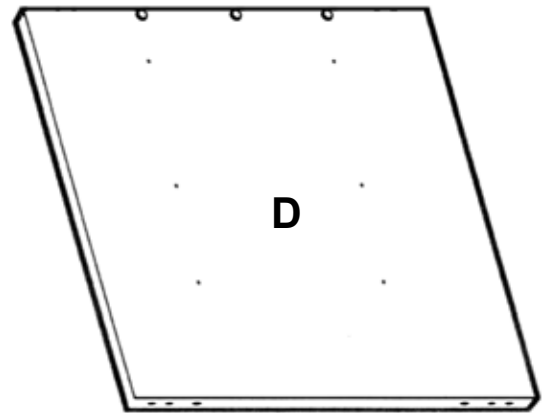

Modesty Panel - CDCU	01011077	1 ea.
Modesty Panel - CDCU29	01013177	1 ea.
Modesty Panel - CDCU39	01011177	1 ea.

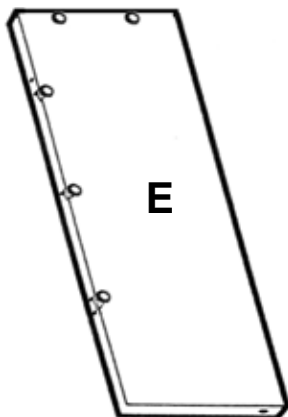

Left Side - CDCU	01011077	1 ea.
Left Side - CDCU29	01013177	1 ea.
Left Side - CDCU39	01011177	1 ea.

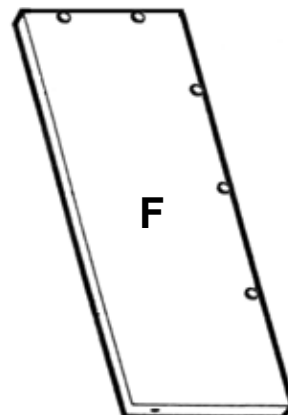

Right Side - CDCU	01011053	1 ea.
Right Side - CDCU29	01013153	1 ea.
Right Side - CDCU39	01011153	1 ea.

HARDWARE



H1	Rafix Flush Cam	909913	13 ea.
----	-----------------	--------	--------



H2	Leveler Insert	274650	6 ea.
----	----------------	--------	-------

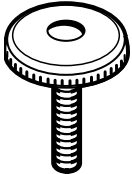

H3	Leveler	300870	6 ea.
----	---------	--------	-------



H4	Rafix Bolt	909923	19 ea.
----	------------	--------	--------



H5	Rafix Cam	909910	6 ea.
----	-----------	--------	-------



H6	Corner Bracket	411170	2 ea.
----	----------------	--------	-------

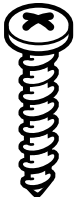

H7	1" Panhead Screw	901227	6 ea.
----	------------------	--------	-------

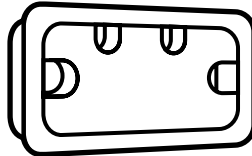

H8	Grommet	286580	4 ea.
----	---------	--------	-------

Hardware for Connecting to Other Glacier Circulation Units

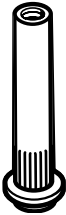

H9	Connector Sleeve	950200	4 ea.
----	------------------	--------	-------

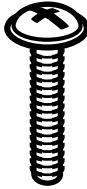

H10	Connector Screw	901350	4 ea.
-----	-----------------	--------	-------

Using the Rafix System:

Insert the Rafix Cams into the appropriate holes. The flat edge of the cam should be facing the edge of the panel.

Slide Rafix Cams of the panel to be attached onto the corresponding posts.

When screwing post into hole, **Do Not** over tighten. Screw post down until bottom face of post flange just touches board surface.

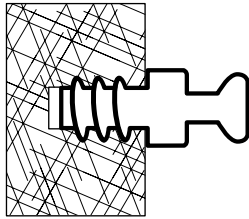

Using a #3 Phillips screwdriver, turn the rotating portion of the Rafix Cam a 1/2 turn clockwise to secure. **IMPORTANT!** Do not exceed 1/2 turn when tightening cams. Turn 1/2 turn counterclockwise to disassemble and remove panel.

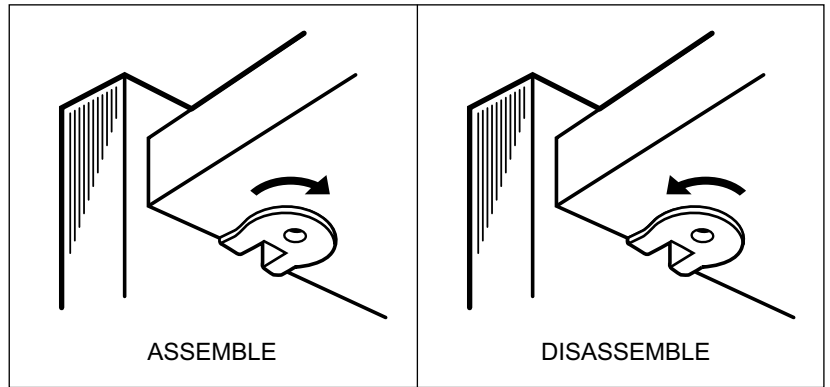
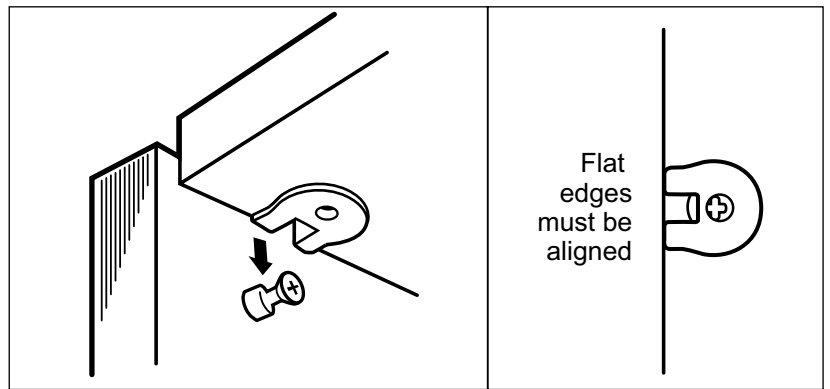

#1

Place the Left Back (E), Modesty Panel (D), and Right Back (F) on a clean, carpeted surface with the pre-drilled holes facing up. Insert five Rafix Flush Cams (H1) into the Left Back, three cams into Modesty Panel, and five cams into Right Back with the arrows of the cams facing out where indicated.

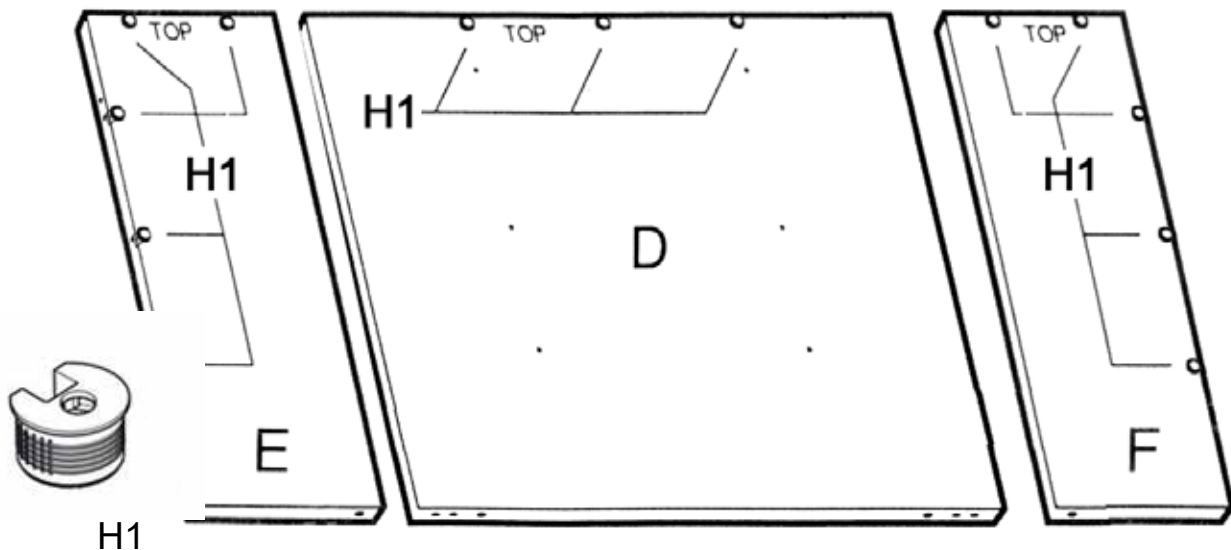

#2

Insert the Leveler Inserts (H2) into the holes in the bottom edge of the Modesty Panel (D). Using a plastic mallet, tap until flush with the surface. Screw the Levelers (H3) into the Leveler Inserts. Adjust Levelers when the assembled unit is in place.

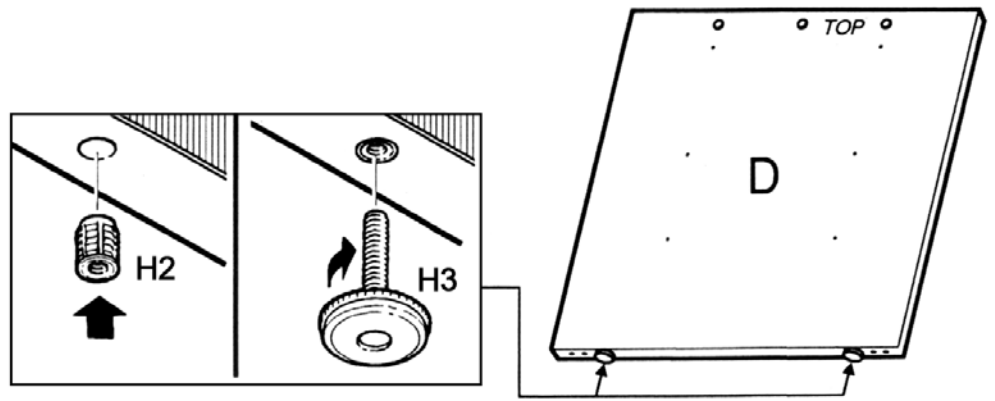

#3

Slightly elevate the Top (C) by placing some packing material underneath it. Insert six Rafix Cams (H5) into the Top with the arrows of the cams facing out.

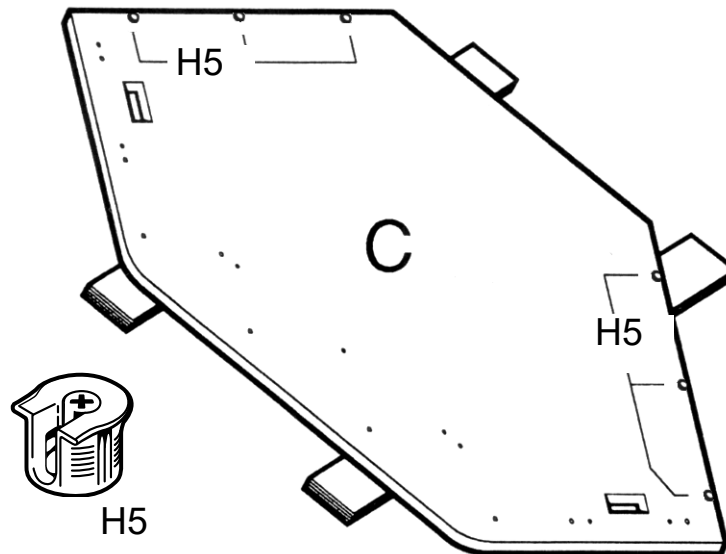

#4

Screw seven Rafix Bolts (H4) into the Top (C) where indicated.

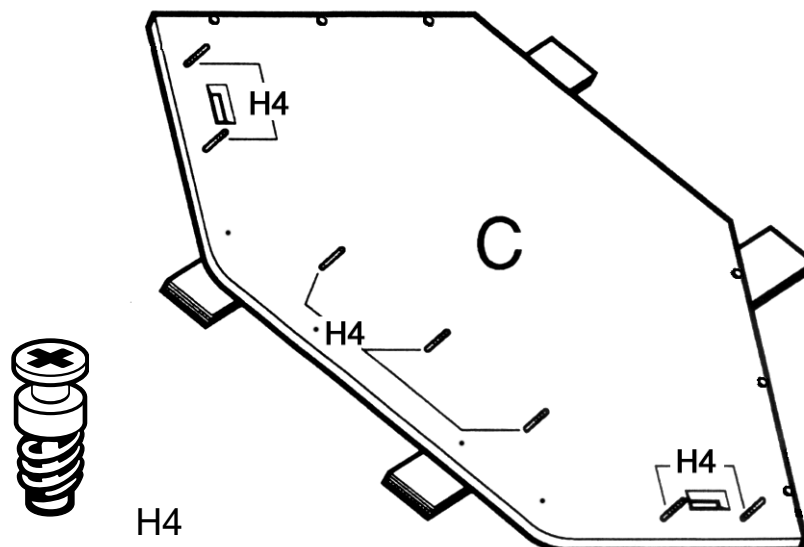

#5

Screw six Rafix Bolts (H4) into the Left Side (A) and Right Side (B) where indicated.

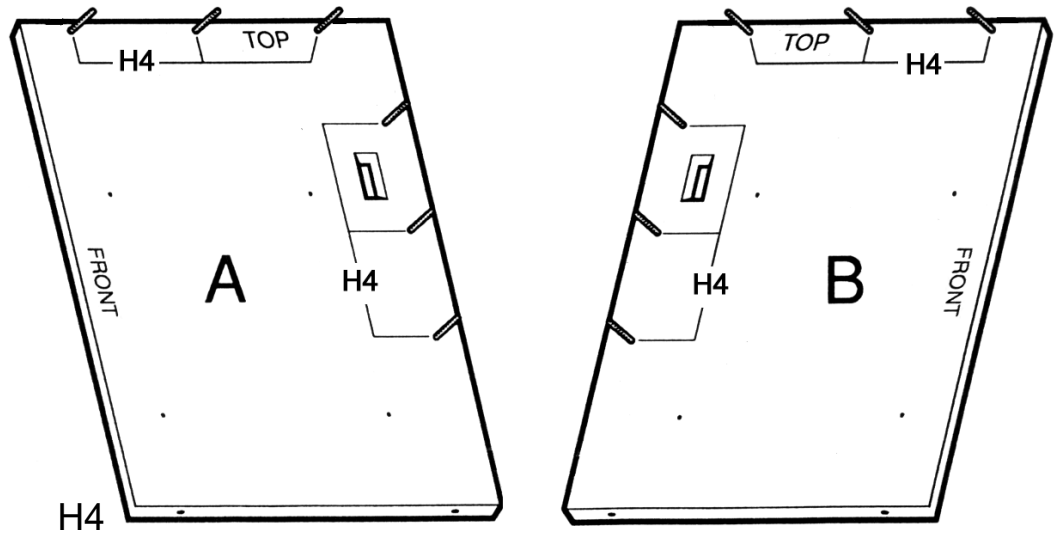

#6

Insert the Leveler Inserts (H2) into the holes in the bottom edges of the Left Side (A) and Right Side (B). Using a plastic mallet, tap until flush with the surface. Screw the Levelers (H3) into the Leveler Inserts. Adjust Levelers when the assembled unit is in place.

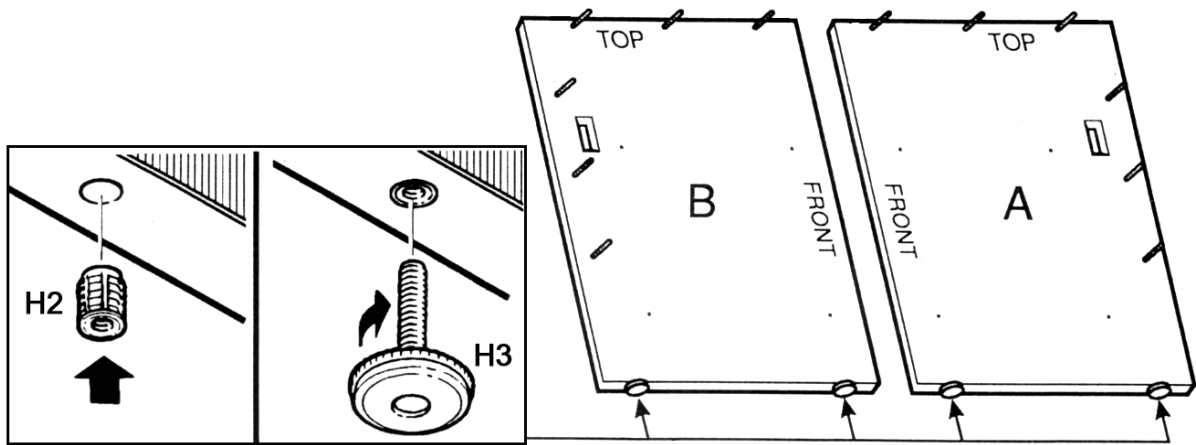

#7

Position the Right Back (F) onto the bolts of the Top (C) and turn the cams (H1) clockwise to secure.

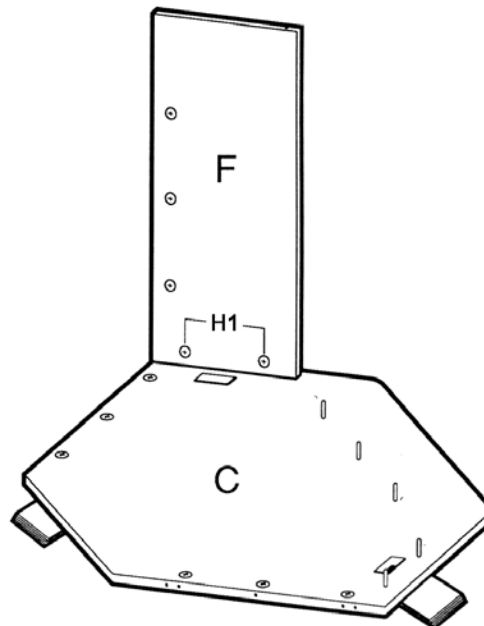

#8

Position the Modesty Panel (D) onto the bolts of the Top (C) and turn the cams (H1) clockwise to secure.

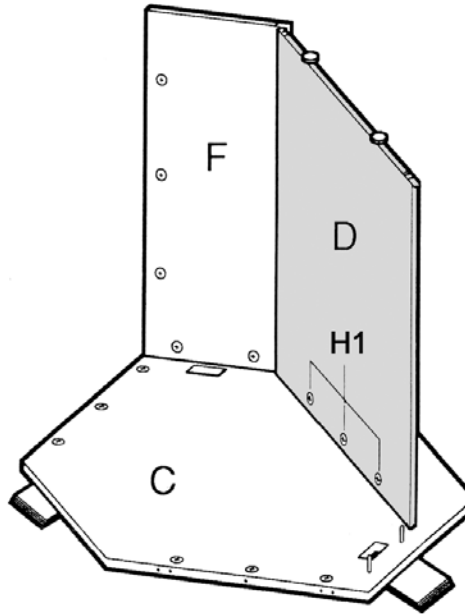

#9

Position the Left Back (E) onto the Top (C) and turn the cams (H1) clockwise to secure.

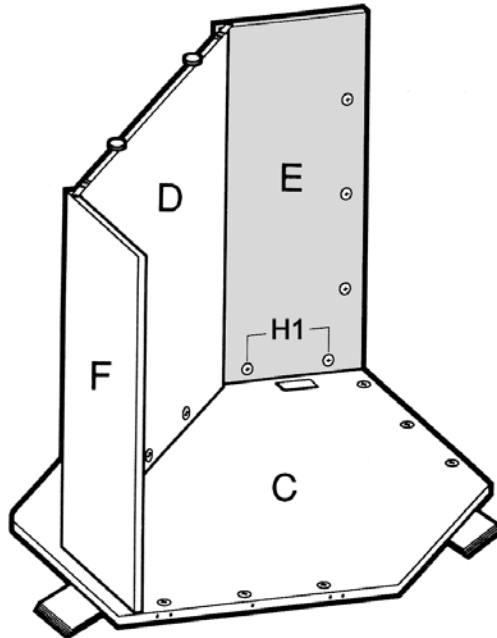

#10

Connect the Left and Right Back (E & F) to the Modesty Panel (D) with the Corner Brackets (H6) using 1" Panhead Screws (H7) in the pre-drilled holes.

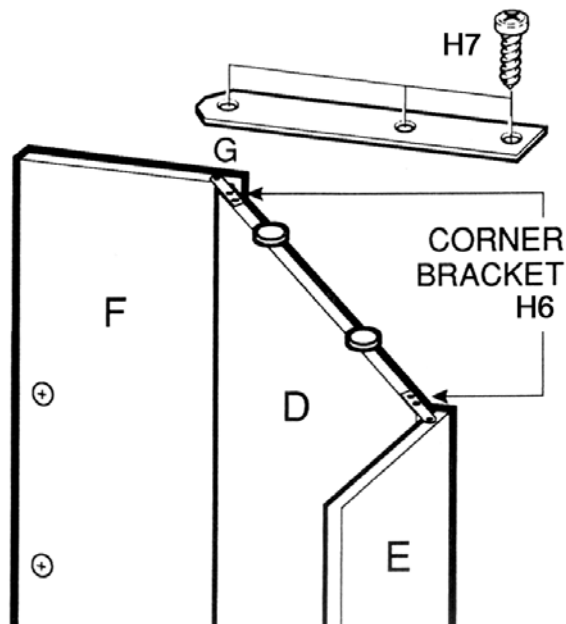

#11

Position the Right Side (B) onto the bolts of the Top (C) as shown. Turn the indicated cams (H1) clockwise to secure the Right Side in place.

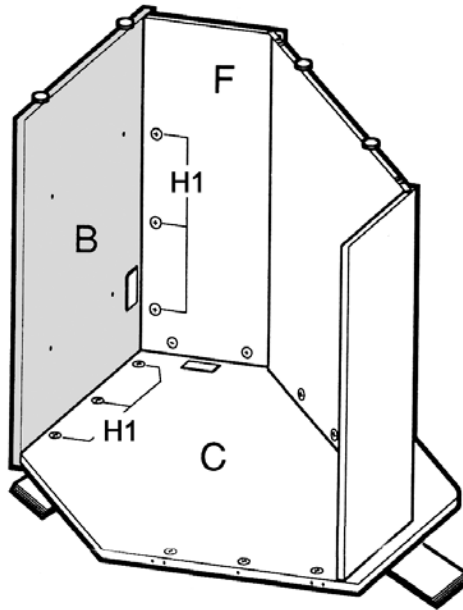

#12

Position the Left Side (A) onto the bolts of the Top as shown. Turn the cams of the Top (C) and the Left Back (E) clockwise to secure the Left Side in place.

With the assistance of another person, turn the unit upright.

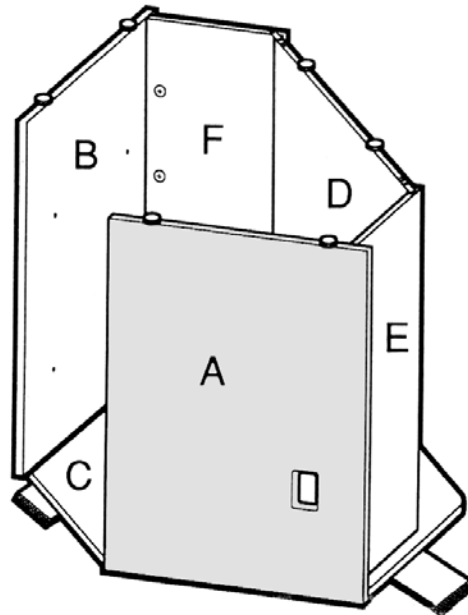

#13

Insert Grommets into the Left Side (A), Right Side (B), and Top (C).

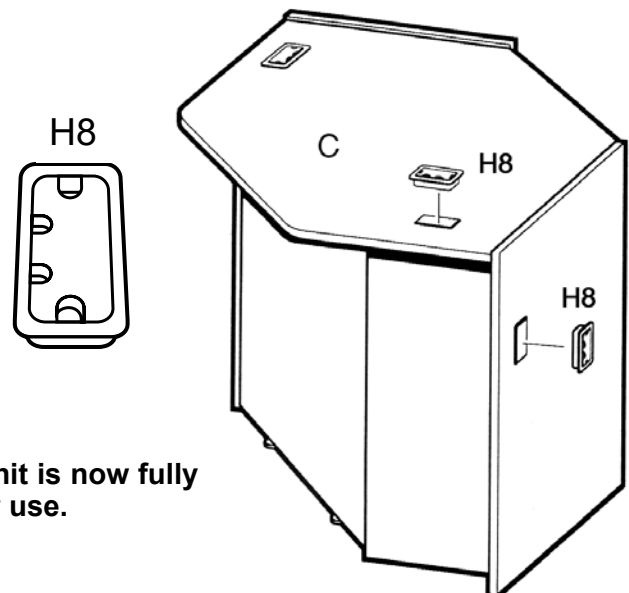

Your Glacier Circulation Corner Unit is now fully assembled and ready for use.

CONNECTING TO OTHER CIRCULATION DESK UNITS:

Remove Grommets from the panels to be connected.

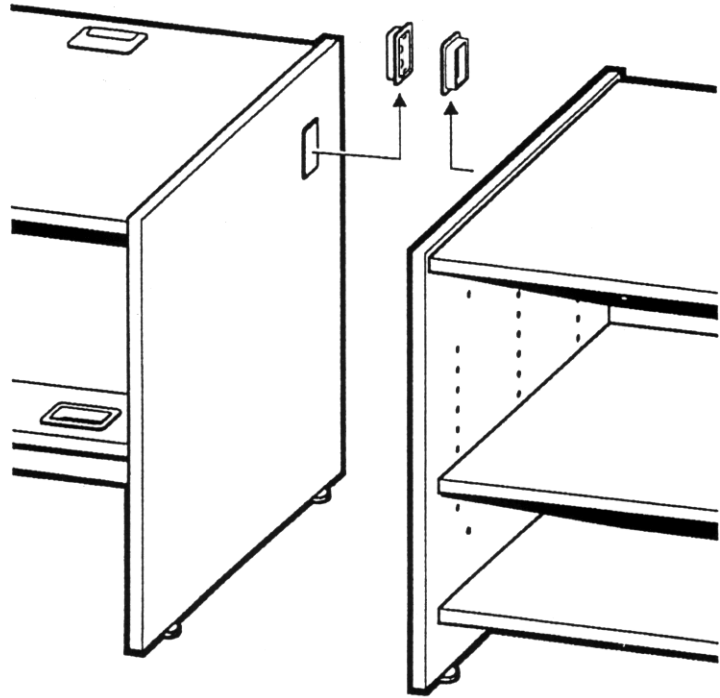

Using a 13/64" bit, drill through the four pilot holes on the inside of each side panel.

Align the side panels of the units to be connected. Tap four Connector Sleeves (H9) through the holes in one side panel and into the holes of the unit to be connected. From the other side, secure the units together using four Connector Screws (H10).

