

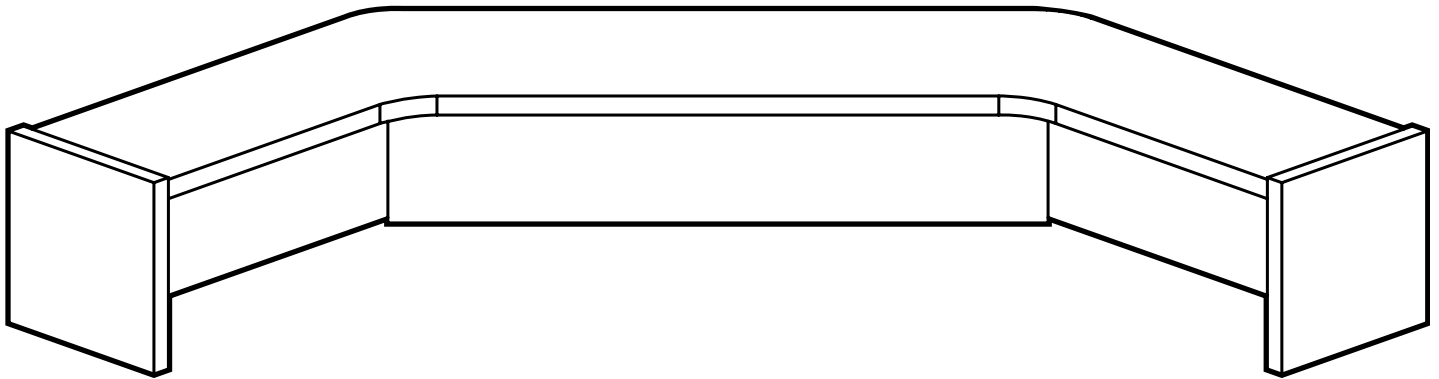

BY  **IRONWOOD**

CDCUR CDCRR

RISER UNIT



IMPORTANT!

Assembly may require the assistance of another person.

Before you begin assembly:

READ THE DIRECTIONS all the way through one time. This will speed up the process and help you understand the sequence of steps.

COUNT THE PARTS AND HARDWARE before assembly. This ensures you have received all necessary parts before you begin.

TOOLS: You may need a Phillips head screwdriver, a medium slotted screwdriver or a plastic mallet. To protect your new furniture from damage during assembly, it is recommended to work on a carpeted surface.

In the event any parts are missing from this package, send your name, address, telephone number, and a description of the missing part(s) to: **PARTS, Box 1420, Missoula, MT 59806** or call: **1-800-769-5693** or **FAX 1-800-445-5281**.

CAUTION: On assemblies requiring glue, make sure the unit is assembled correctly before gluing. Once this unit is assembled with glue, the manufacturer will not be responsible for damaged parts. Keep a damp cloth or sponge handy to wipe off excess glue.

To care for this furniture, simply wipe with a cloth dampened with glass cleaner containing ammonia-D.

PARTS DIAGRAM

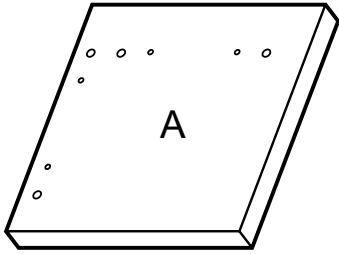

Left Side	01011642	1 ea.
-----------	----------	-------

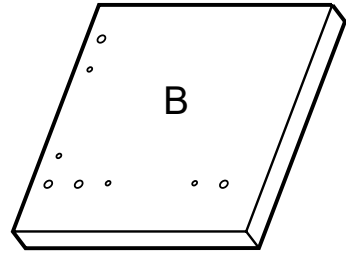

Right Side	01011643	1 ea.
------------	----------	-------

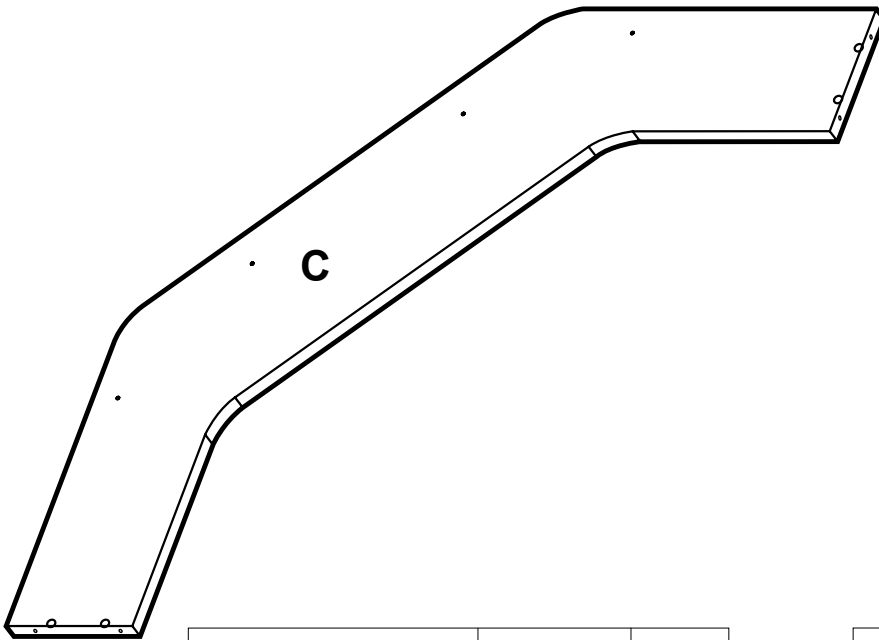

Top CDCUR	01050801	1 ea.
Top CDCRR	01050501	1 ea.

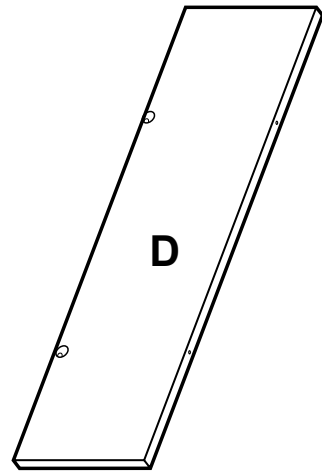

Back CDCUR	01050852	1 ea.
Back CDCRR	01050552	1 ea.

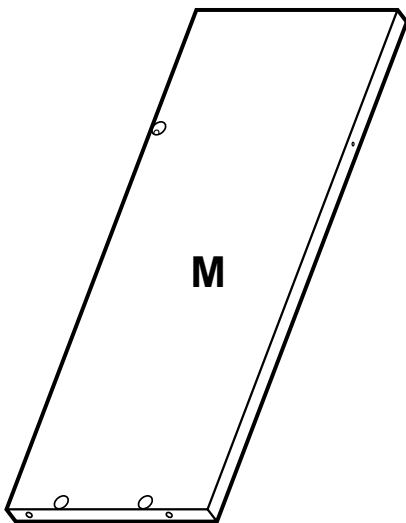

Left Back CDCUR	01050854	1 ea.
Left Back CDCRR	01050554	1 ea.

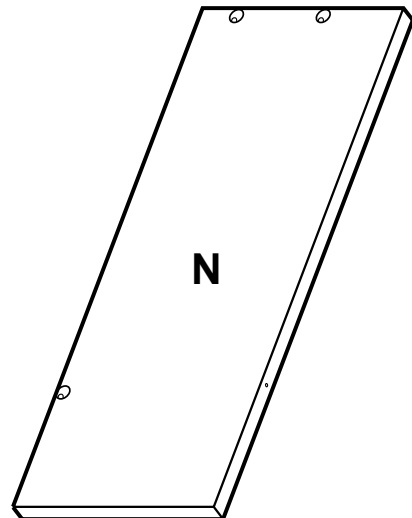

Right Back CDCUR	01050854	1 ea.
Right Back CDCRR	01050554	1 ea.

HARDWARE

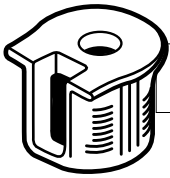

H1	Rafx Cam	909909	4 ea.
----	----------	--------	-------



H2	Rafx Bolt	909923	25 ea.
----	-----------	--------	--------



H3	Flush Rafx Cam	909911	8 ea.
----	----------------	--------	-------



H4	Double-Sided Tape	298525	6 ft
----	-------------------	--------	------

Using the Rafx System:

Insert the Rafx Cams into the appropriate holes. The flat edge of the cam should be facing the edge of the panel.

Slide Rafx Cams of the panel to be attached onto the corresponding posts.

When screwing post into hole, **Do Not** over tighten. Screw post down until bottom face of post flange just touches board surface.

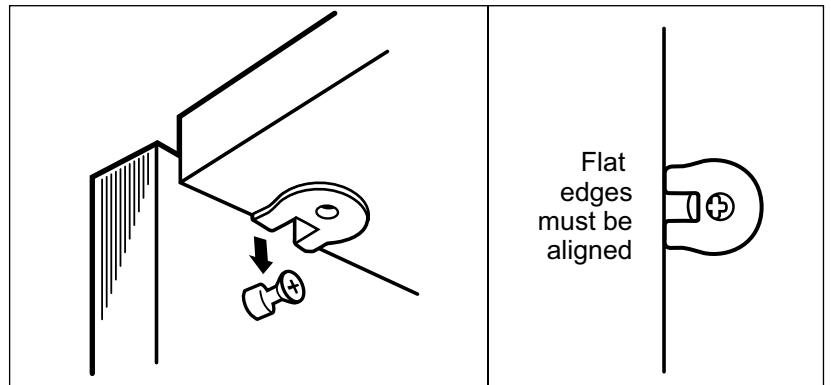
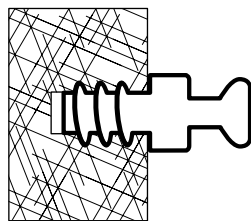

Using a #3 Phillips screwdriver, turn the rotating portion of the Rafx Cam a 1/2 turn clockwise to secure. **IMPORTANT!** Do not exceed 1/2 turn when tightening cams. Turn 1/2 turn counterclockwise to disassemble and remove panel.

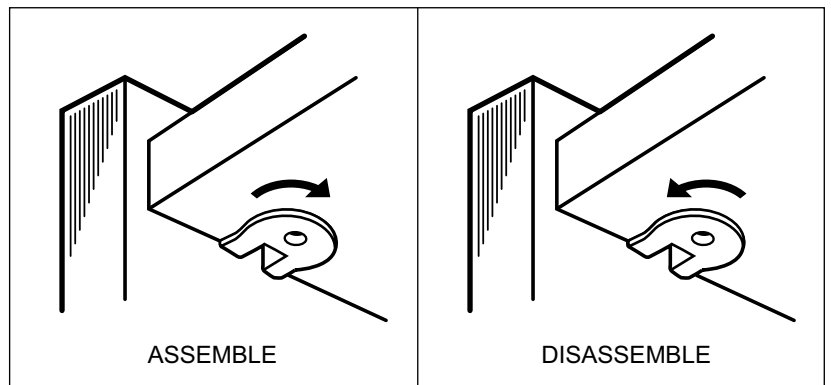

#1

Insert four Rafix Cams (H1) and screw four Rafix Bolts (H2) into the Top Panel (C) as shown.

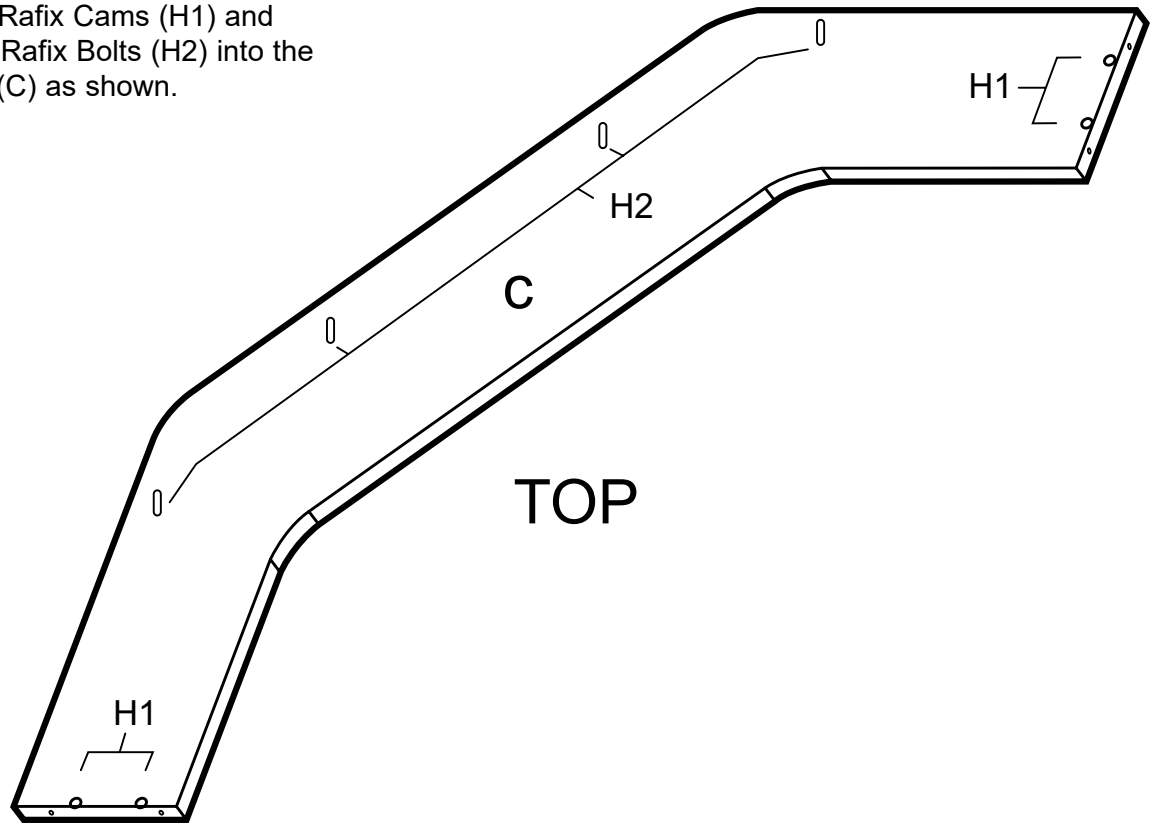

#2

Screw four Rafix Bolts (H2) into each Side Panel (A & B) as shown.

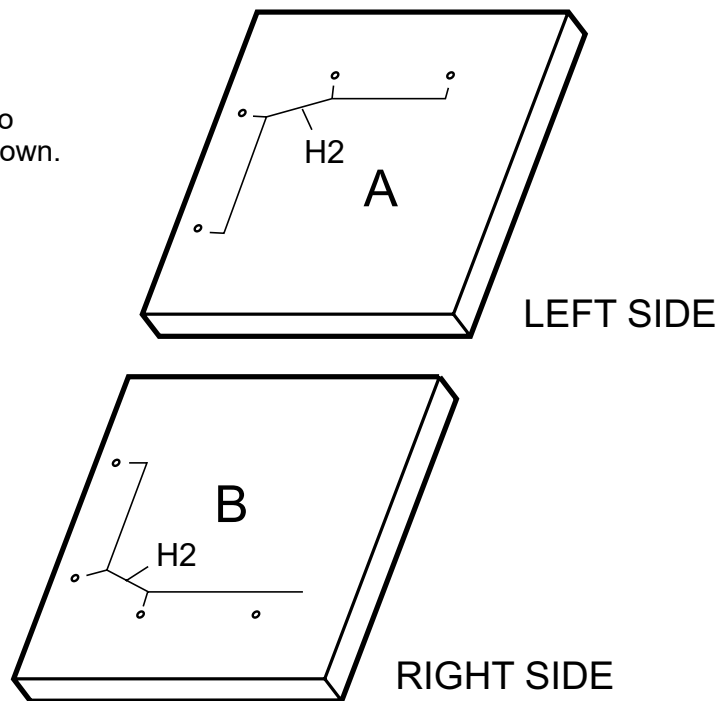

#3

Insert Flush Rafix Cams (H3) into each Back Panel (M,N,D) as shown, making sure the arrow faces out toward the edge of the panel.



H3

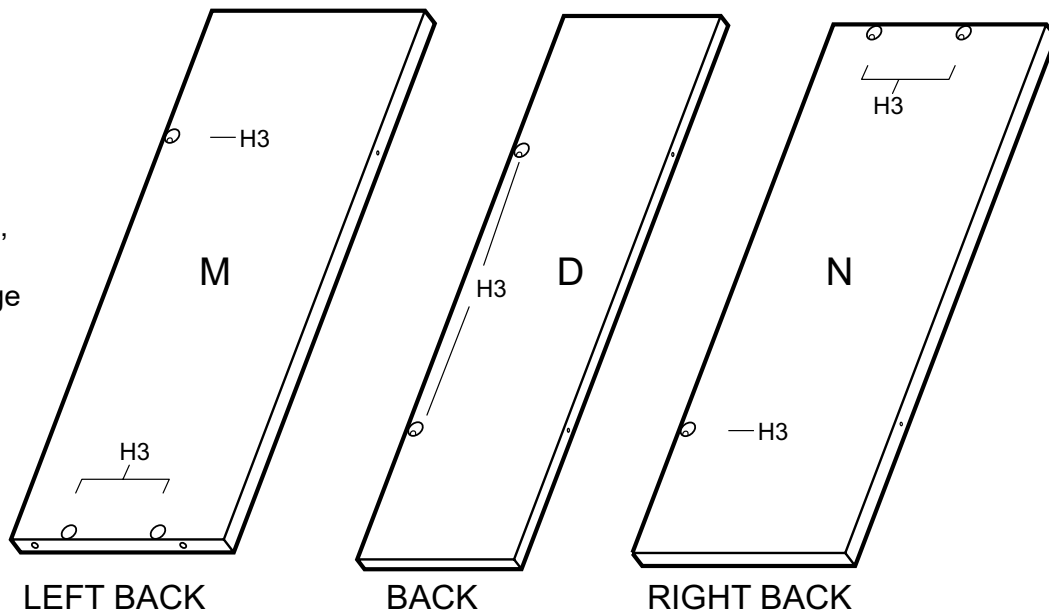

#4

Attach the Back Panel (D) to the Top (C) as shown. Turn the Flush Rafix Cams (H3) clockwise to tighten.

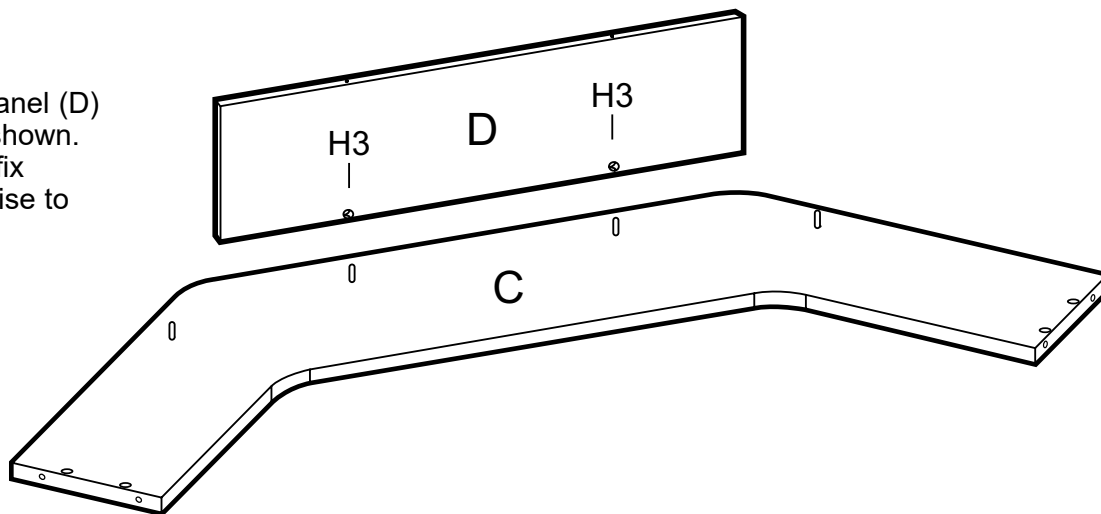

#5

Attach the Left Back (M) as shown. Turn the Flush Rafix Cam (H3) clockwise to tighten.

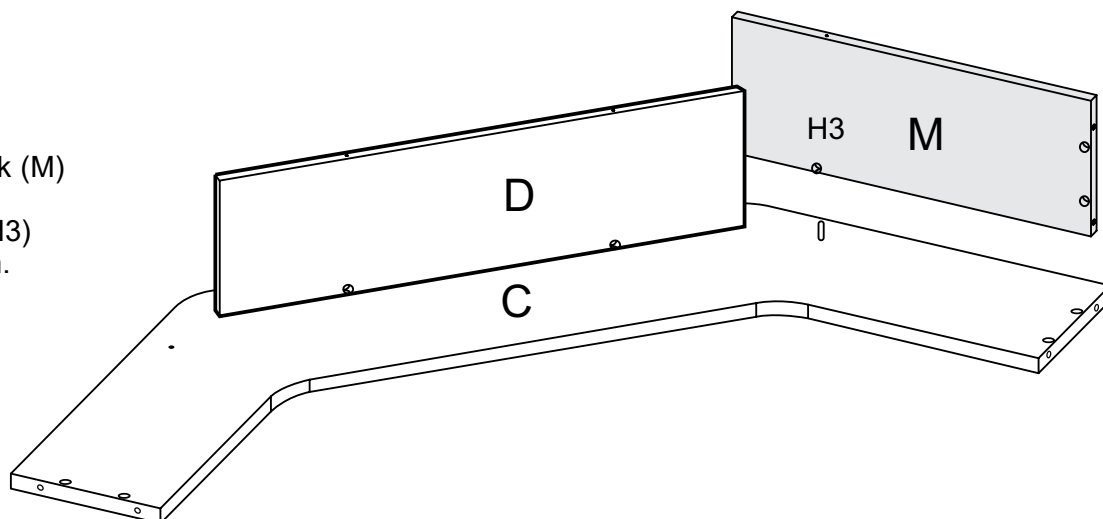

#6

Attach the Right Back (N) as shown. Turn the Flush Rafix Cam (H3) clockwise to tighten.

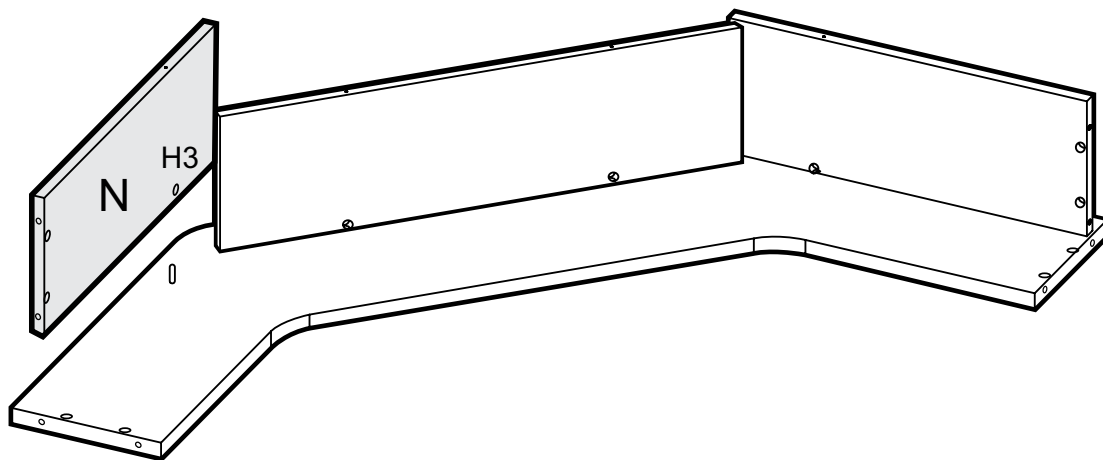

#7

Attach the Left Side as shown. Turn the Rafix Cams(H1) and Flush Rafix Cams (H3) clockwise to tighten.

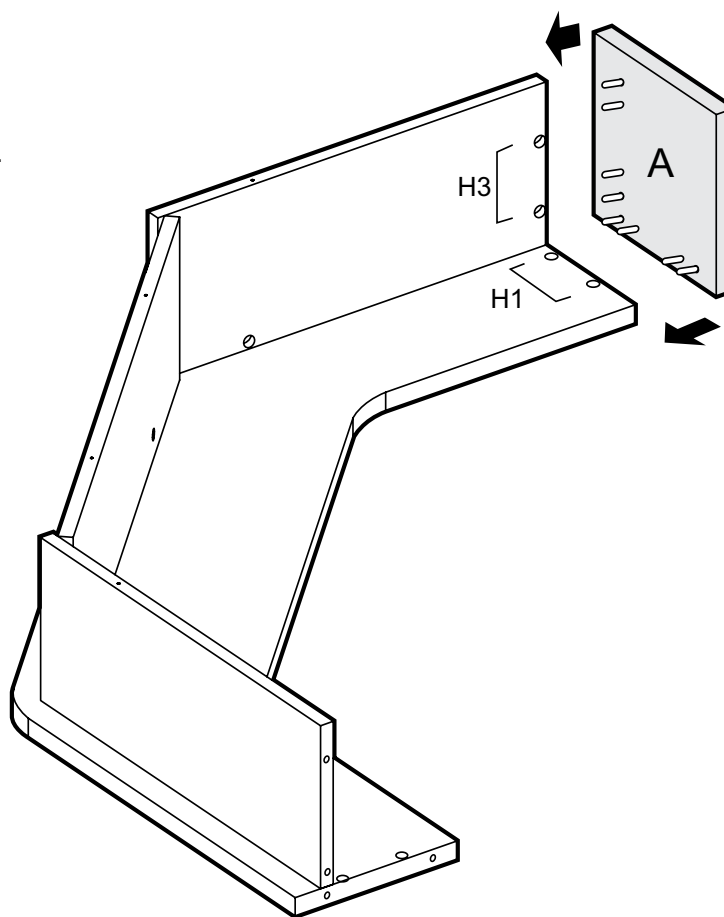

#8

Attach the Right Side (B) as shown. Turn the Rafx Cams (H1) and Flush Rafx Cams (H3) clockwise to tighten.

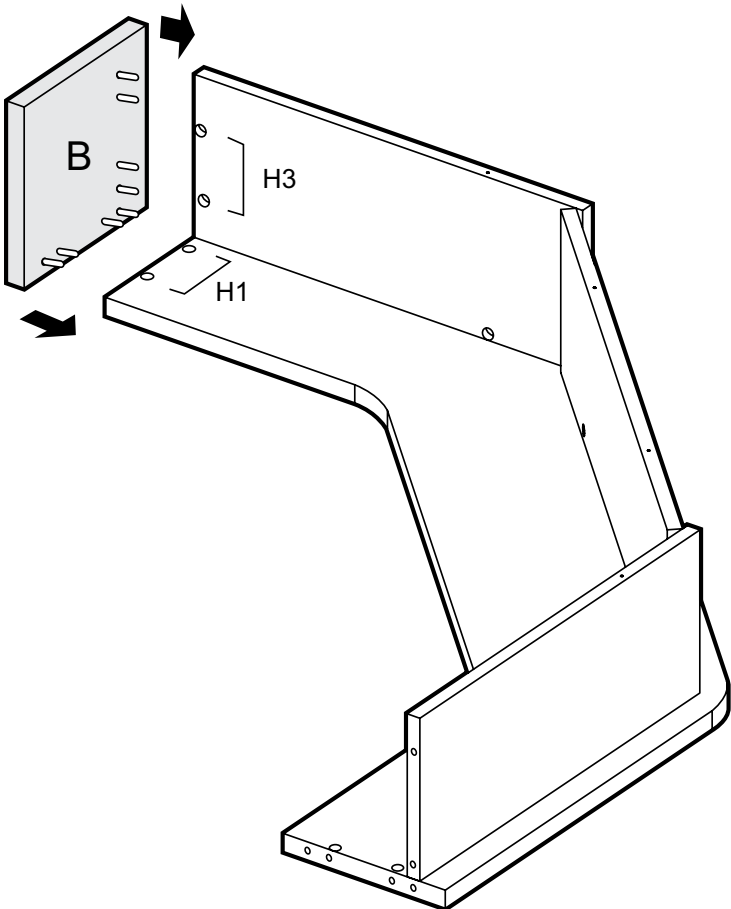

#9

ATTACHING THE UNIT TO THE DESKTOP:

Attach with double-sided tape (H4)

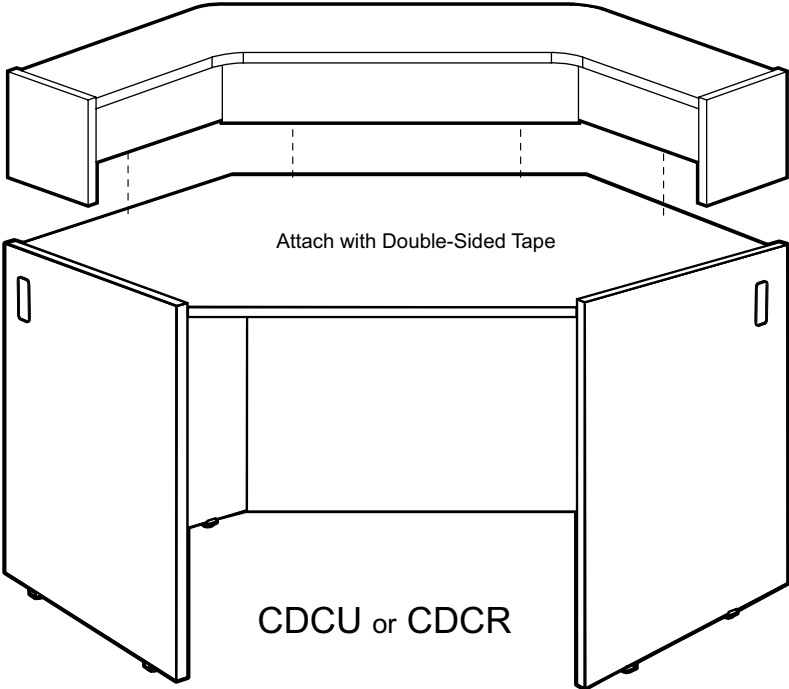

The installation of your Glacier Corner Riser unit is now complete and ready to use.