

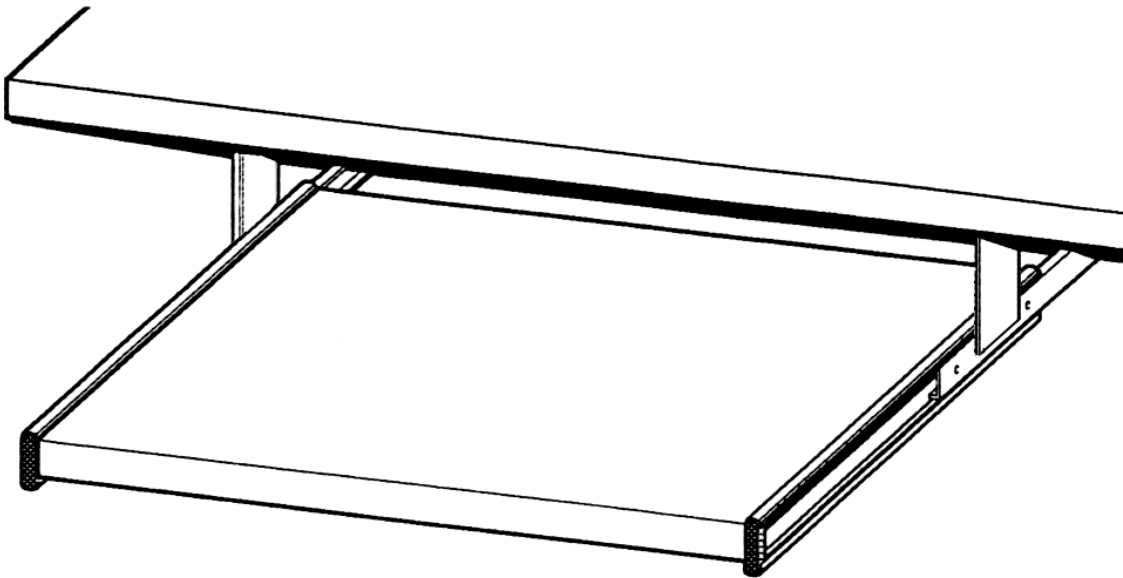

BY  IRONWOOD

CDKS/CDKS2/MKS

KEYBOARD SHELF



IMPORTANT!

Assembly may require the assistance of another person.

Before you begin assembly:

READ THE DIRECTIONS all the way through one time. This will speed up the process and help you understand the sequence of steps.

COUNT THE PARTS AND HARDWARE before assembly. This ensures you have received all necessary parts before you begin.

TOOLS: You may need a Phillips head screwdriver, a medium slotted screwdriver or a plastic mallet. To protect your new furniture from damage during assembly, it is recommended to work on a carpeted surface.

In the event any parts are missing from this package, send your name, address, telephone number, and a description of the missing part(s) to: PARTS, Box 1420, Missoula, MT 59806 or call: 1-800-769-5693 or FAX 1-800-445-5281.

CAUTION: On assemblies requiring glue, make sure the unit is assembled correctly before gluing. Once this unit is assembled with glue, the manufacturer will not be responsible for damaged parts. Keep a damp cloth or sponge handy to wipe off excess glue.

To care for this furniture, simply wipe with a cloth dampened with glass cleaner containing ammonia-D.

PARTS DIAGRAM

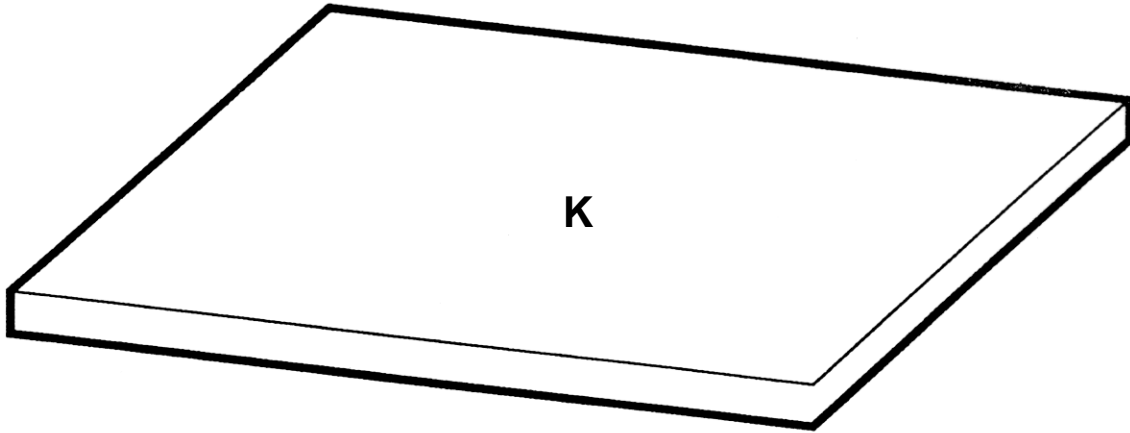

Keyboard Shelf – CDKS	01011827	1 ea.
Keyboard Shelf – CDKS2	01013427	1 ea.

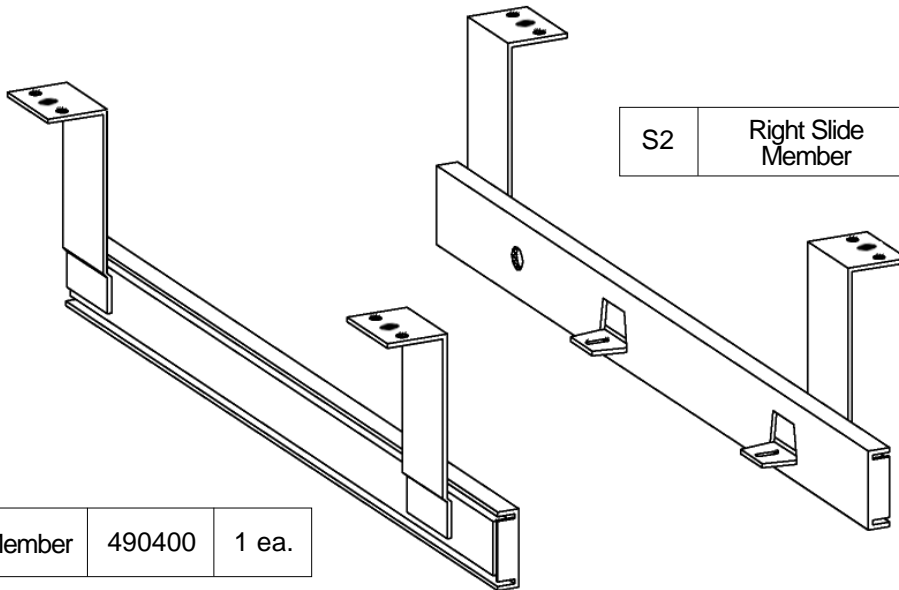

S1	Left Slide Member	490400	1 ea.
----	-------------------	--------	-------

S2	Right Slide Member	490450	1 ea.
----	--------------------	--------	-------



H1	#10 x 5/8" Panhead Screw	901220	16 ea.
----	-----------------------------	--------	--------

#1

Use the enclosed template to mark and drill the mounting holes on the underside of your worksurface.

#2

Position the Left Slide Member (S1) and the Right Slide Member (S2) onto the underside of the worksurface as shown.

Attach the Slide Members (S1 & S2) using four #8 x 3/4" Panhead Screws (H1) into the pre-drilled holes of the underside of the worksurface. **Do not fully tighten screws yet.**

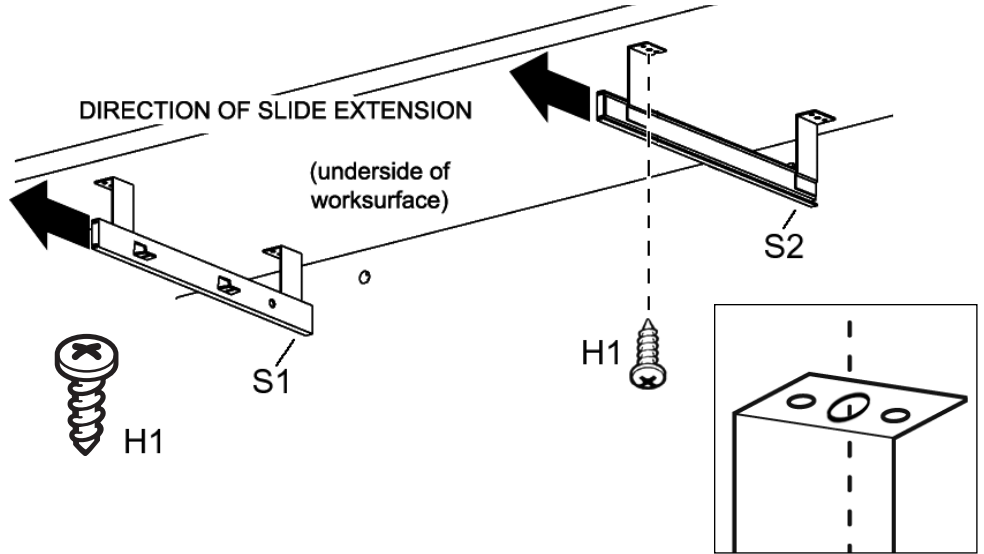

#3

Fully extend the Slides (S1 & S2). Place the Keyboard Shelf (K) onto the flanges of the Slides (S1 & S2). Attach using four #8 x 3/4" Panhead Screws (H1) into the pre-drilled holes in the underside of the Keyboard Shelf.

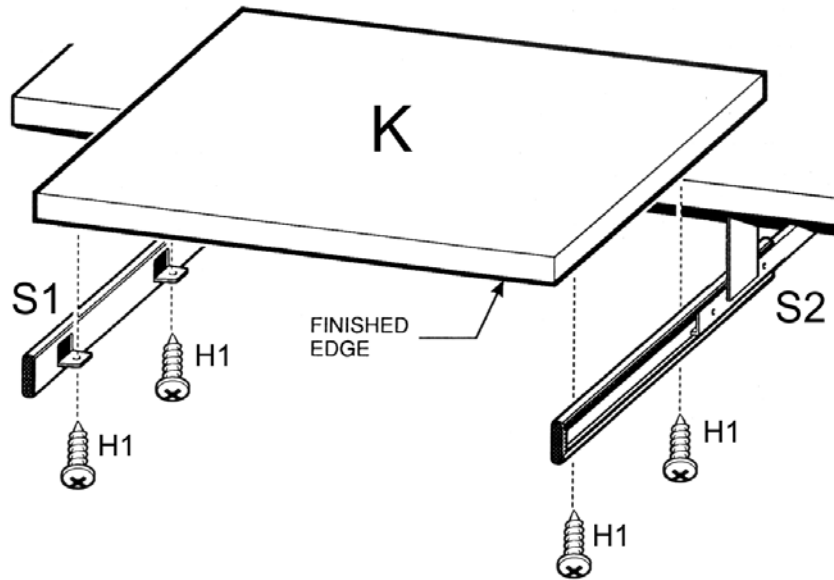

#4

Tighten the four screws on the underside of the worksurface. Screw eight additional screws (H1) into the underside of worksurface through the remaining holes of the slides.

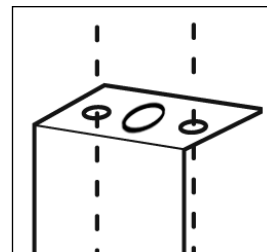

Your Glacier-Ironwood Keyboard is now fully installed and ready for use.