



BY  **IRONWOOD**

LIBRARY FURNITURE

LFMD

FREESTANDING MAGAZINE DISPLAY

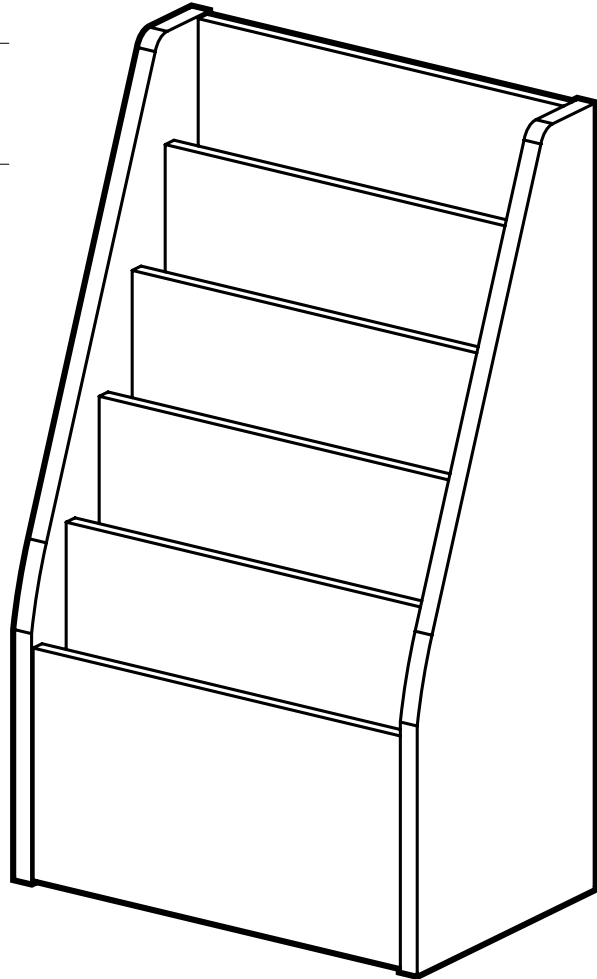

IMPORTANT!

Assembly may require the assistance of another person.

Before you begin assembly:

READ THE DIRECTIONS all the way through one time. This will speed up the process and help you understand the sequence of steps.

COUNT THE PARTS AND HARDWARE before assembly. This ensures you have received all necessary parts before you begin.

TOOLS: You may need a Phillips head screwdriver, a medium slotted screwdriver or a plastic mallet. To protect your new furniture from damage during assembly, it is recommended to work on a carpeted surface.

In the event any parts are missing from this package, send your name, address, telephone number, and a description of the missing part(s) to: **PARTS, Box 1420, Missoula, MT 59806** or call: **1-800-769-5693** or **FAX 1-800-445-5281**.

CAUTION: On assemblies requiring glue, make sure the unit is assembled correctly before gluing. Once this unit is assembled with glue, the manufacturer will not be responsible for damaged parts. Keep a damp cloth or sponge handy to wipe off excess glue.

To care for this furniture, simply wipe with a cloth dampened with glass cleaner containing ammonia-D.

PARTS DIAGRAM

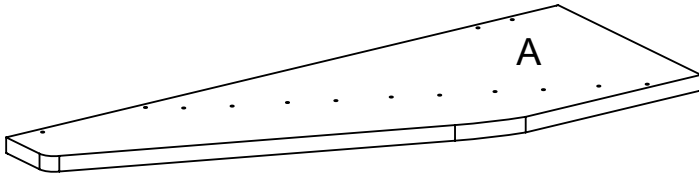

Left Panel	07010642	1 ea.
------------	----------	-------

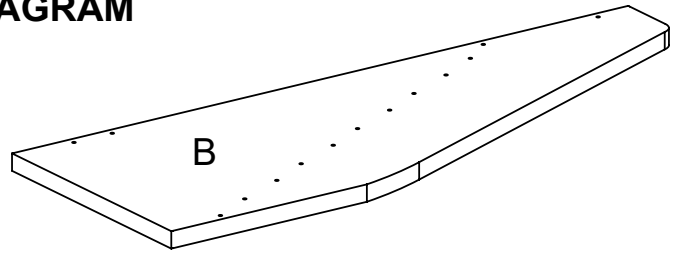

Right Panel	07010642	1 ea.
-------------	----------	-------

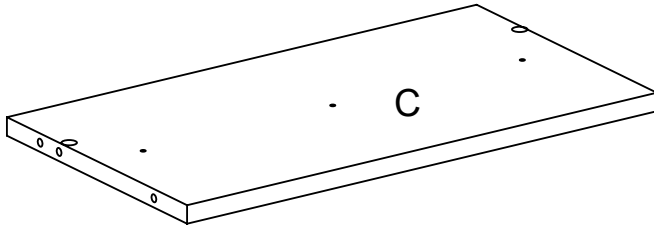

Front Panel	07010680	1 ea.
-------------	----------	-------

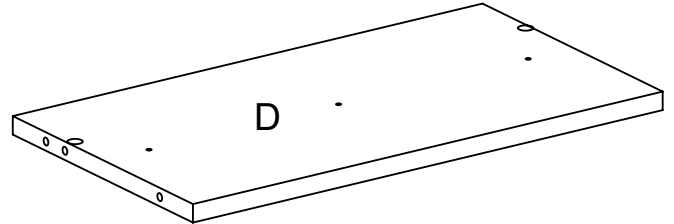

Magazine Back	07010680	4 ea.
---------------	----------	-------

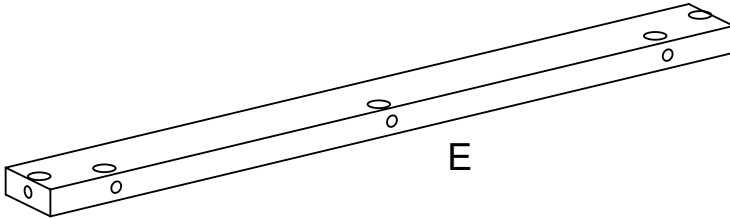

Shelf Panel	07010636	5 ea.
-------------	----------	-------

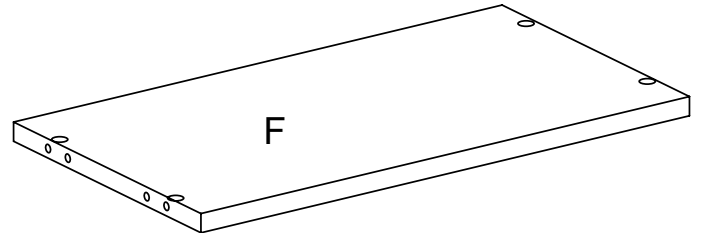

Back Panel	07010657	1 ea.
------------	----------	-------

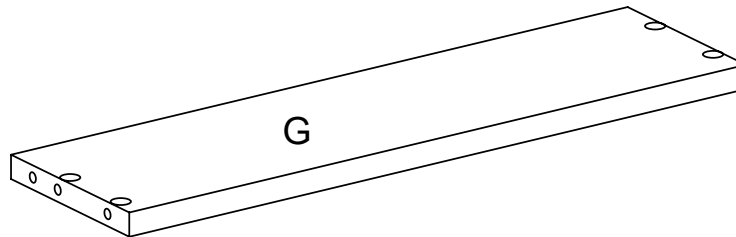

Back Spanner	07010660	1 ea.
--------------	----------	-------

PARTS DIAGRAM



H1	Flush Rafix Cam	909911	14 ea.
----	-----------------	--------	--------



H3	Rafix Bolt	909925	43 ea.
----	------------	--------	--------



H2	Rafix Cam	909910	29 ea.
----	-----------	--------	--------

Using the Rafix System:

Insert the Rafix Cams into the appropriate holes. The flat edge of the cam should be facing the edge of the panel.

Slide Rafix Cams of the panel to be attached onto the corresponding posts.

When screwing post into hole, **Do Not** over tighten. Screw post down until bottom face of post flange just touches board surface.

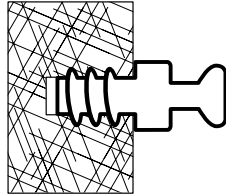

Using a #3 Phillips screwdriver, turn the rotating portion of the Rafix Cam a 1/2 turn clockwise to secure. **IMPORTANT!** Do not exceed 1/2 turn when tightening cams. Turn 1/2 turn counterclockwise to disassemble and remove panel.

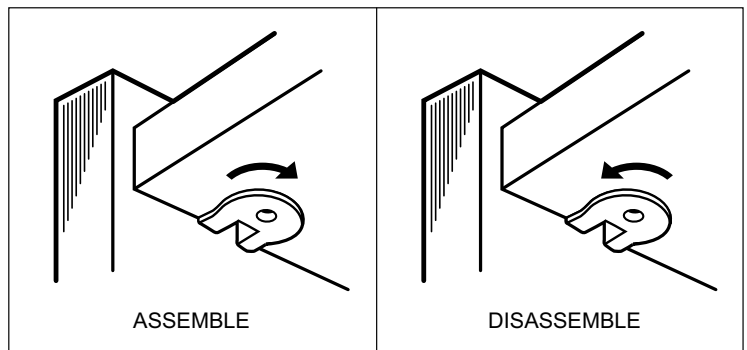
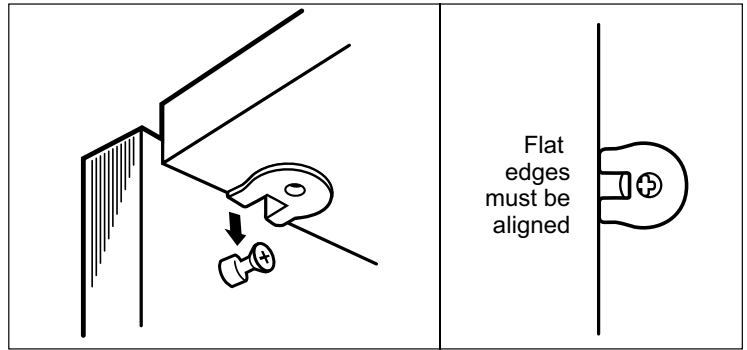

#1

Screw in Rafix Bolts (H3) to Right Panel (B) and Left Panel (A).

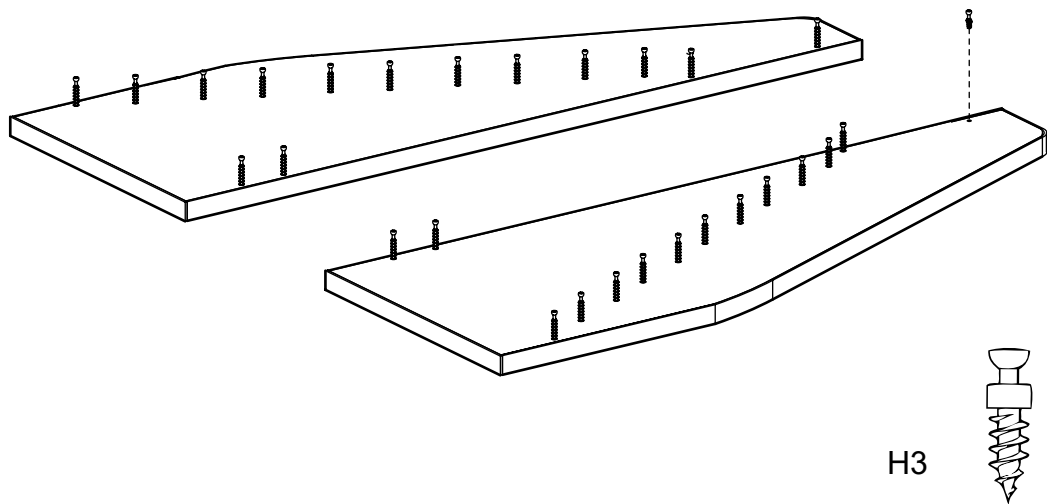

#2

Screw in Rafix bolt (H3) and push in Flush Rafix Cam (H1) to Front Panel (C) and Magazine Back Panel (D).

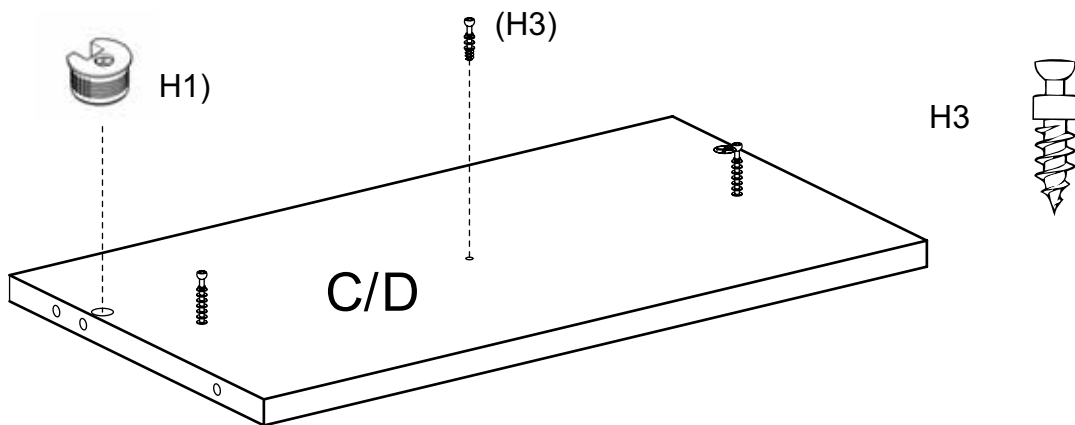

#3

Push in Rafix Cams (H2) into Shelf Panel (E).

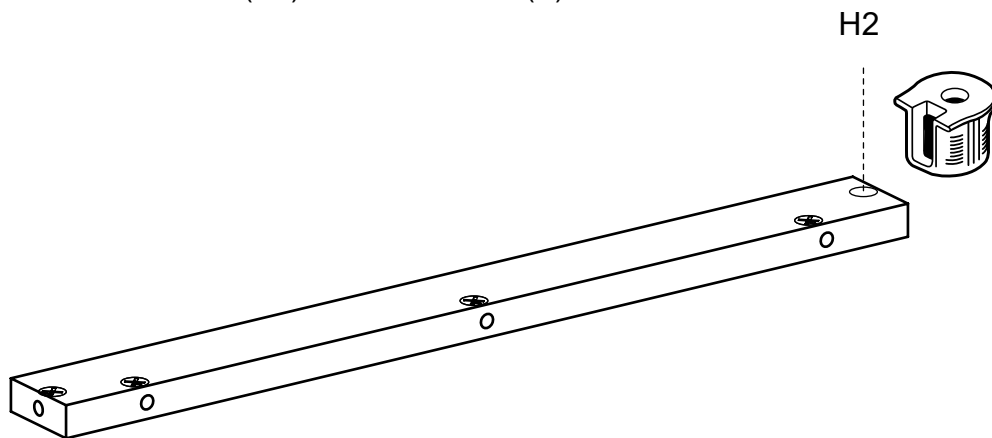

#4

Push in Flush Rafix Cams (H1) into Back Panel (F).

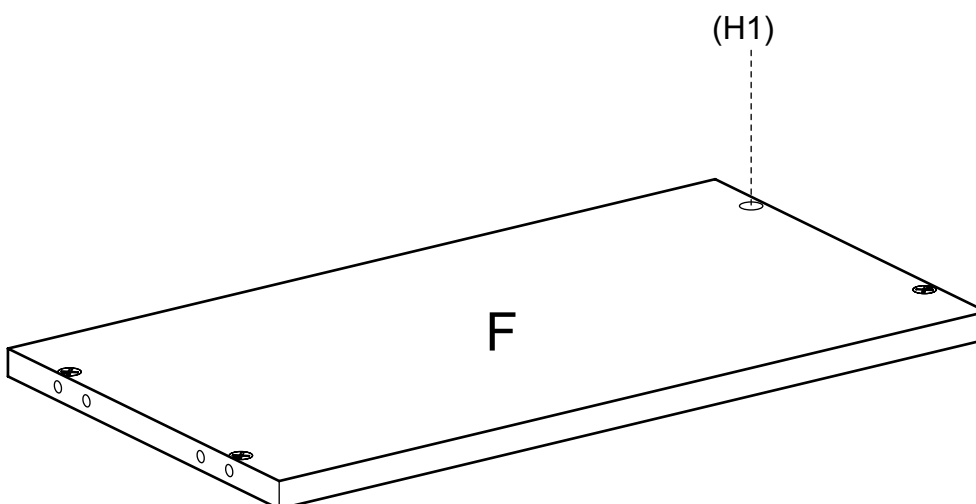

#5

Push in Rafix Cams (H2) into Back Spanner (g).

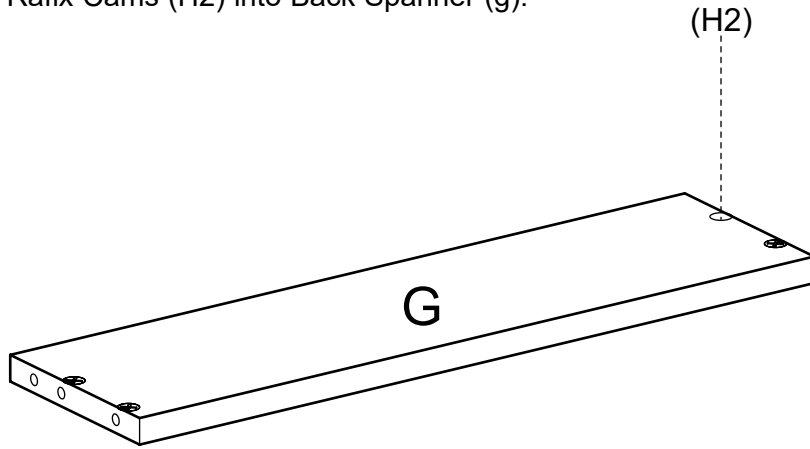

#6

Attach Shelf Panel (E) to Front Panel (C) and Magazine Back (D). Secure in place by turning Rafix Cams (H2).

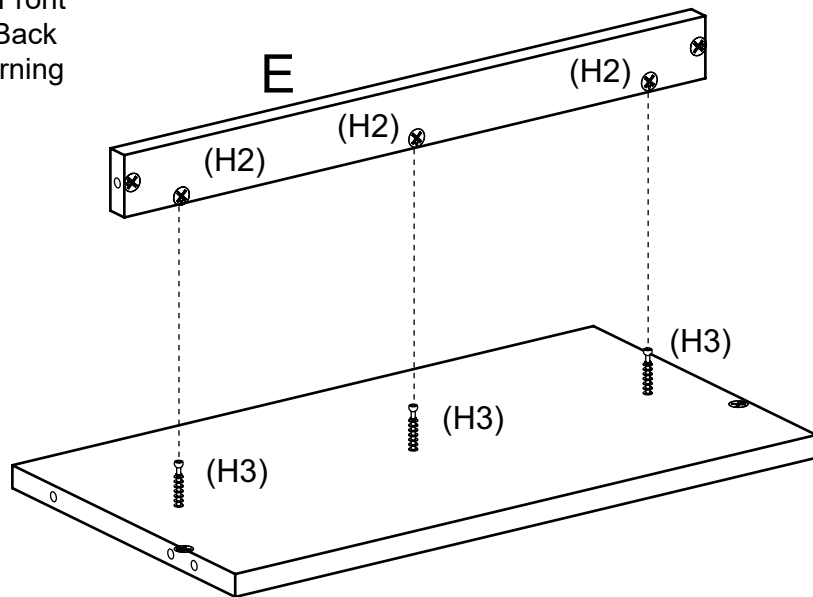

#7

Attach Front Panel (C) and Shelf Panel (D) to Left Panel (A). Secure in place

Note: Must start with Front Panel and work towards the back.

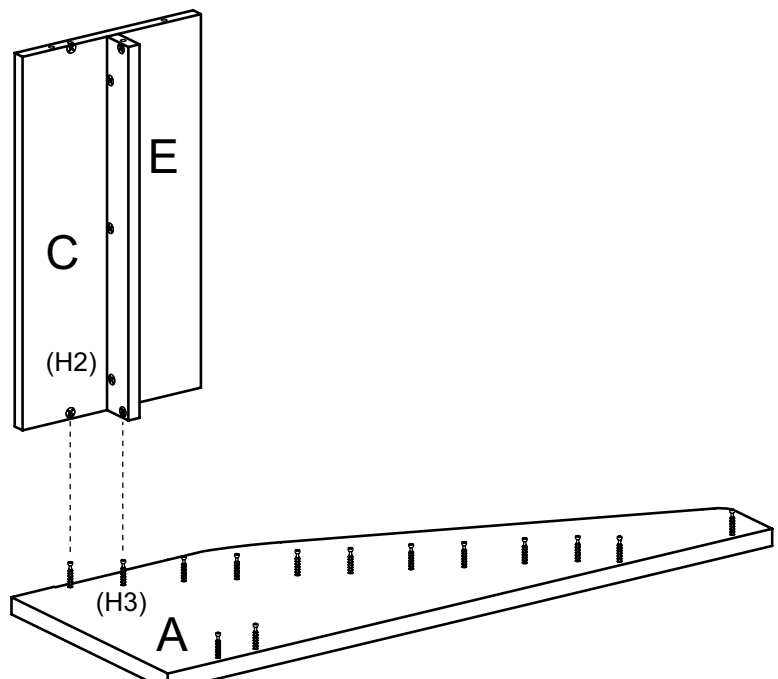

#8

Attach Magazine Back Panel (D) and Shelf Panel (A).
Secure by turning cams.
Repeat with the remaining 3
Magazine Back/Shelf sub
assemblies.

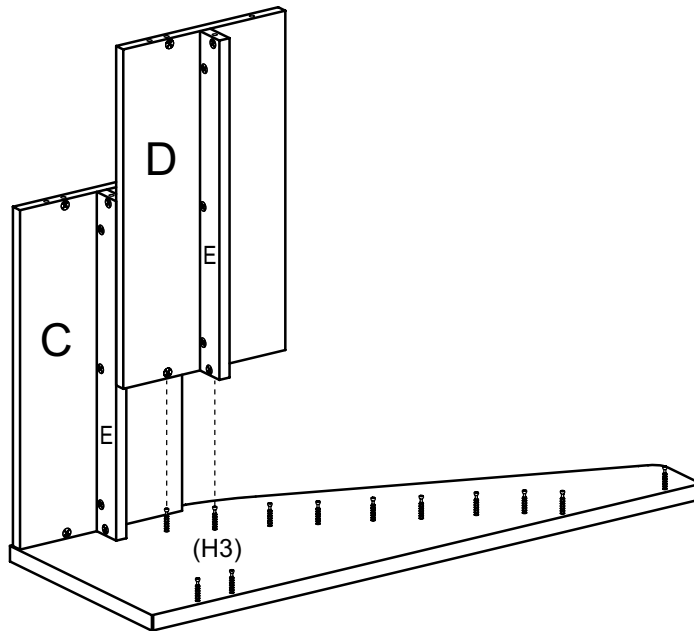

#9

Attach Back Panel (F) to Left Panel (A).
Secure using Cams

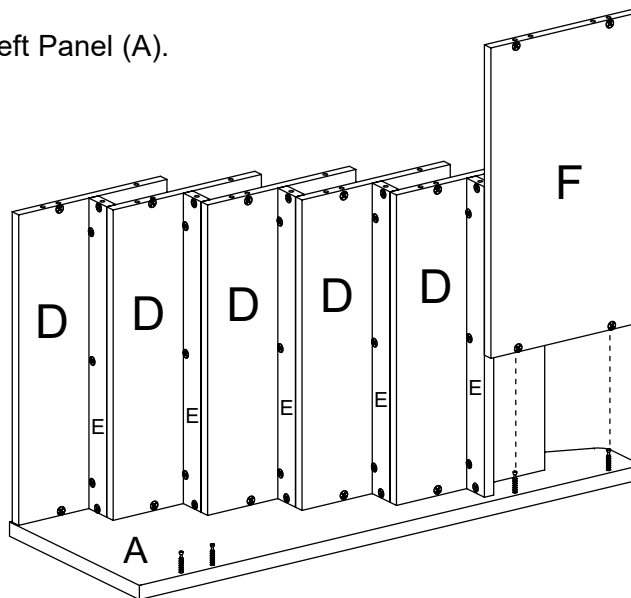

#10

Attach Spanner (G) to
Left Panel (A). Secure
using cams

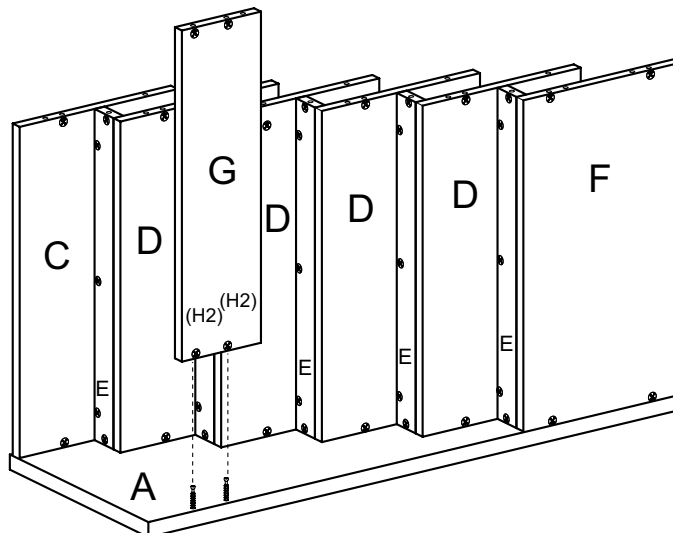

#11

Attach Right Panel (B) to unit.
Secure using Cams

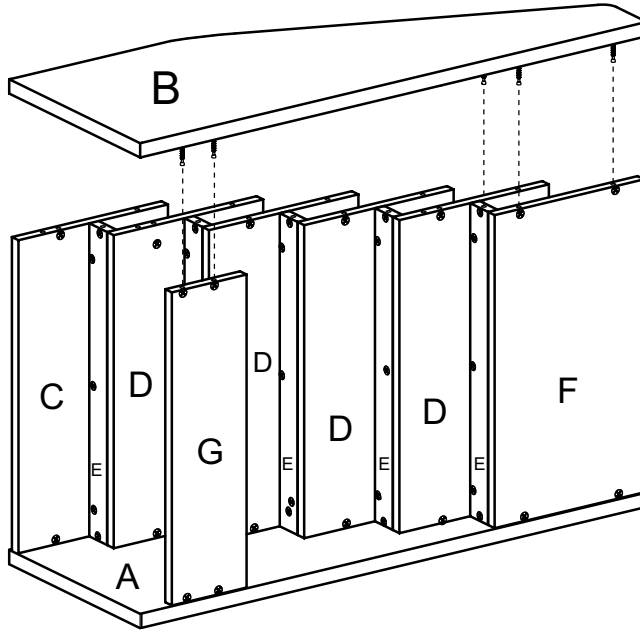

#12

Stand upright, assembly
is complete.

