



BY  **IRONWOOD**

## LIBRARY SHELVING UNIT

**LS42DB LS48DB  
LS60DB LS72DB  
LS84DB**

## DOUBLE BASE UNIT

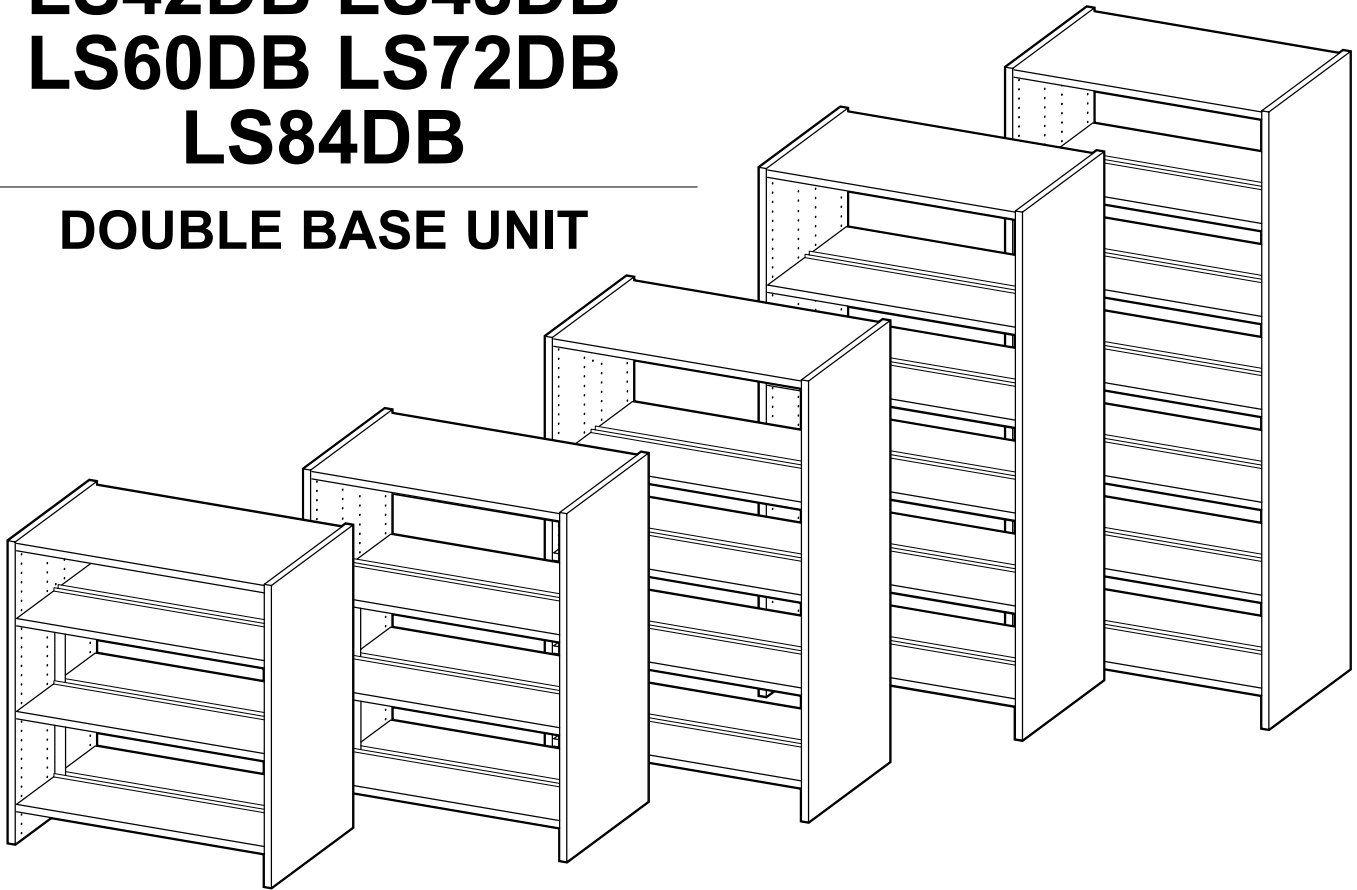

Thank you for purchasing Ironwood Shelving. Please consult your local building codes when installing shelving. It is recommended that all single face shelving be attached to the wall, while double face shelving over 60" in height should be attached to the floor. These are guide lines and vary from state to state.

### IMPORTANT!

Assembly may require the assistance of another person.

Before you begin assembly:

**READ THE DIRECTIONS** all the way through one time. This will speed up the process and help you understand the sequence of steps.

**COUNT THE PARTS AND HARDWARE** before assembly. This ensures you have received all necessary parts before you begin.

**TOOLS:** You may need a Phillips head screwdriver, a medium slotted screwdriver or a plastic mallet. To protect your new furniture from damage during assembly, it is recommended to work on a carpeted surface.

In the event any parts are missing from this package, send your name, address, telephone number, and a description of the missing part(s) to: **PARTS, Box 1420, Missoula, MT 59806** or call: **1-800-769-5693** or **FAX 1-800-445-5281**.

**CAUTION:** On assemblies requiring glue, make sure the unit is assembled correctly before gluing. Once this unit is assembled with glue, the manufacturer will not be responsible for damaged parts. Keep a damp cloth or sponge handy to wipe off excess glue.

To care for this furniture, simply wipe with a cloth dampened with glass cleaner containing ammonia-D.

## PARTS DIAGRAM

The diagram show one size for ease of viewing. Any differences will be indicated in each part's description.

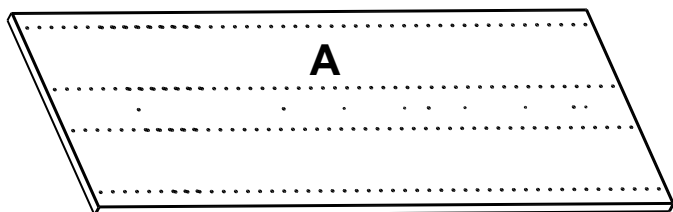

Side	LS42DB	01300141	2 ea.
	LS48DB		2 ea.
	LS60DB		2 ea.
	LS72DB		2 ea.
	LS84DB		2 ea.

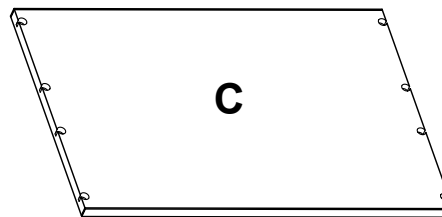

Top	01300101	1 ea.
-----	----------	-------

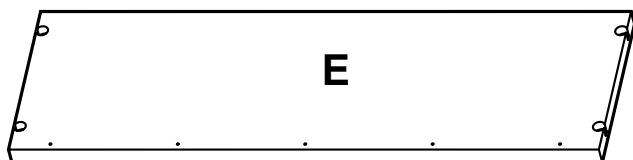

Fixed/ Adjustable Shelf	LS42DB	01200124	6 ea.
	LS48DB		6 ea.
	LS60DB		8 ea.
	LS72DB		10 ea.
	LS84DB		12 ea.

## HARDWARE



H1	Rafix Cam	909910	LS42DB - 16 ea. LS48DB - 16 ea. LS60DB - 16 ea. LS72DB - 16 ea. LS84DB - 16 ea.
----	-----------	--------	---

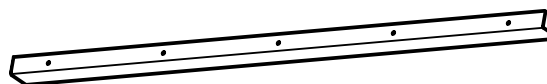

H2	Book Stop	412226	LS42DB - 6 ea. LS48DB - 6 ea. LS60DB - 8 ea. LS72DB - 10 ea. LS84DB - 12 ea.
----	-----------	--------	--



H3	# 8 x 5/8" Panhead Screw	988056	LS42DB - 40 ea. LS48DB - 40 ea. LS60DB - 50 ea. LS72DB - 60 ea. LS84DB - 70 ea.
----	--------------------------------	--------	---



H4	Rafix Bolt	909923	16 ea.
----	------------	--------	--------



H6	Rafix Shelf Pin	909924	16 ea.
----	-----------------	--------	--------

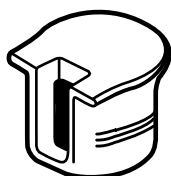

H5	Rafix Shelf Cam	909912	LS42DB - 16 ea. LS48DB - 16 ea. LS60DB - 24 ea. LS72DB - 32 ea. LS84DB - 40 ea.
----	--------------------	--------	---

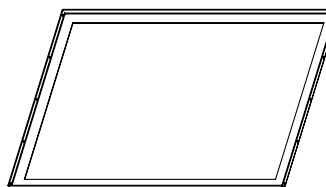

H7	Metal Frame	412026	1 ea.
----	-------------	--------	-------

**If you have purchased an Adder unit  
to be assembled in conjunction with this Base unit,**

it is important to read all the way through the Adder instructions (enclosed in the Adder carton) before beginning. It will be necessary to substitute a Divider (J) for a Right Side (B) during assembly.

**If you have purchased the Back option or the Toe Space option  
to be assembled in conjunction with this Base unit,**

it is important to read through the Back option and/or Toe Space option directions before beginning.

**NOTE:**

**The diagrams show one size for ease of viewing.  
Any differences will be indicated in each step's text.**

### Using the Rafix System:

Insert the Rafix Cams into the appropriate holes. The flat edge of the cam should be facing the edge of the panel.

Slide Rafix Cams of the panel to be attached onto the corresponding posts.

When screwing post into hole, **Do Not** over tighten. Screw post down until bottom face of post flange just touches board surface.

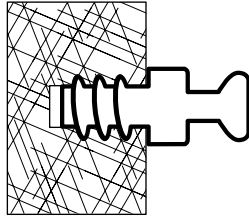

Using a #3 Phillips screwdriver, turn the rotating portion of the Rafix Cam a 1/2 turn clockwise to secure. **IMPORTANT!** Do not exceed 1/2 turn when tightening cams. Turn 1/2 turn counterclockwise to disassemble and remove panel.

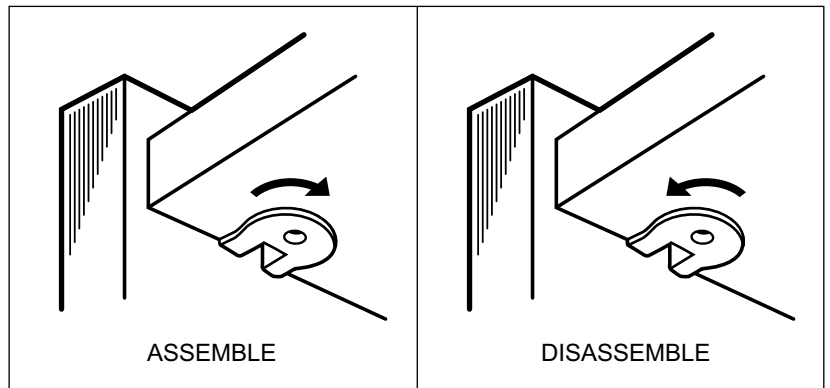
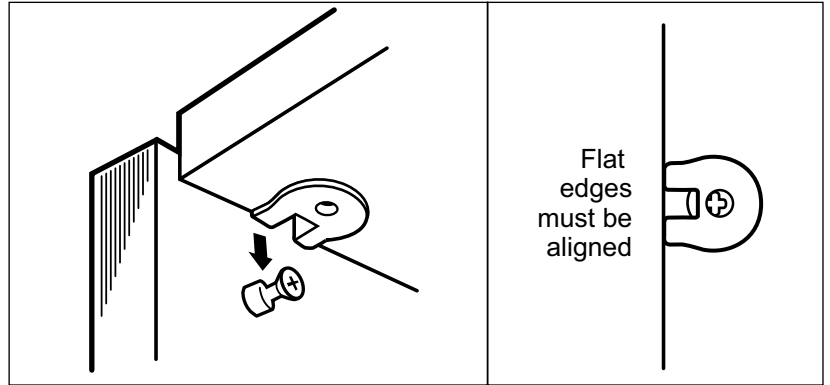

#1

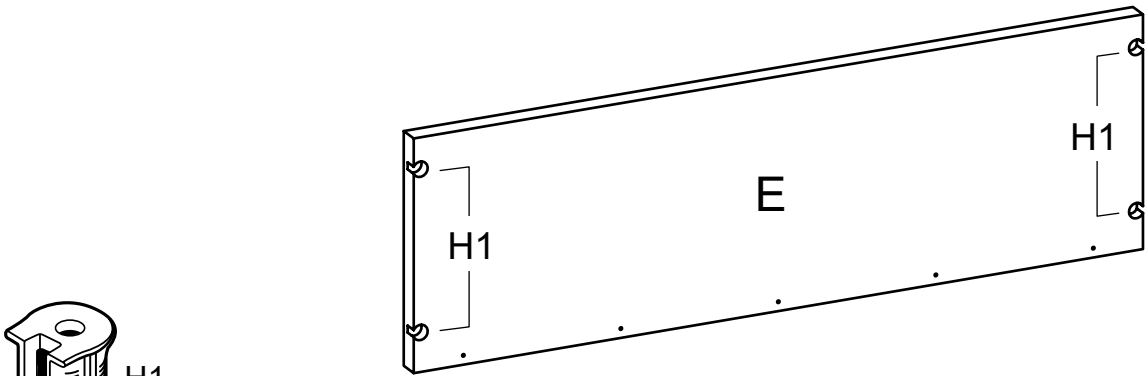
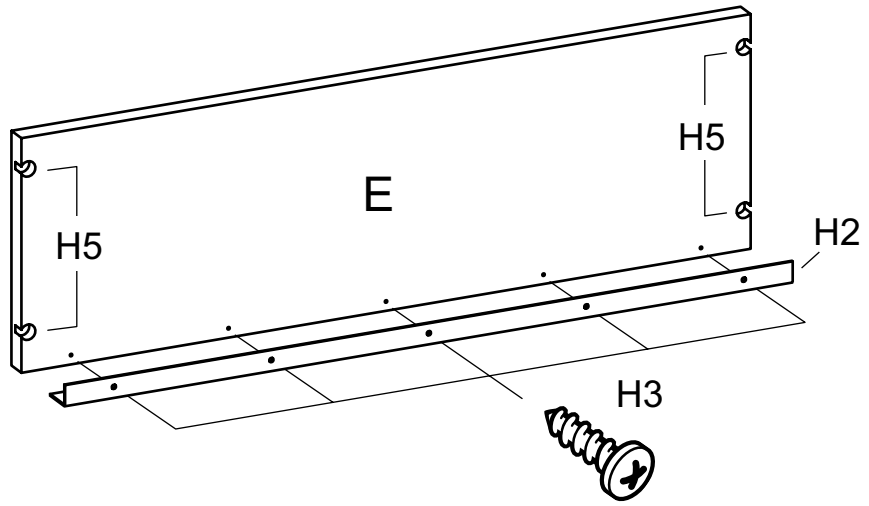

#2

Install eight Rafix Cams (H1) into the Top Panel (C) as shown.

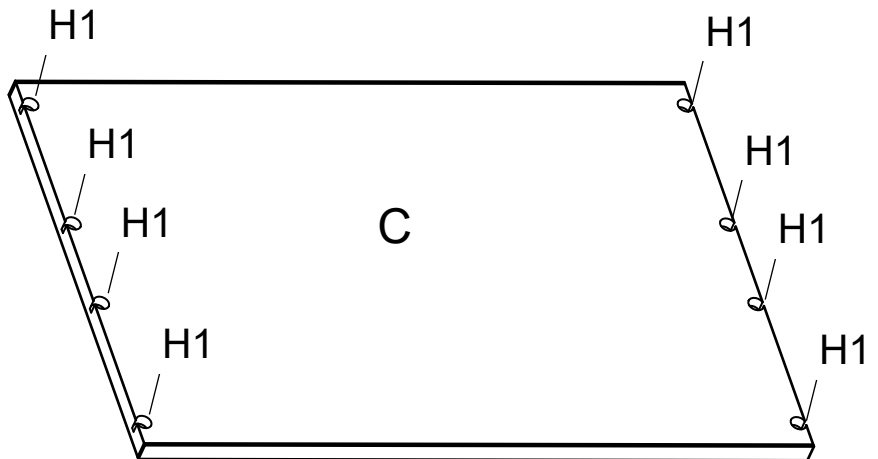

#3

Place both Side (A)'s on a clean, carpeted surface as shown. Place Rafix bolts (H4) in each Side Panel into the selected pre-drilled holes as indicated.

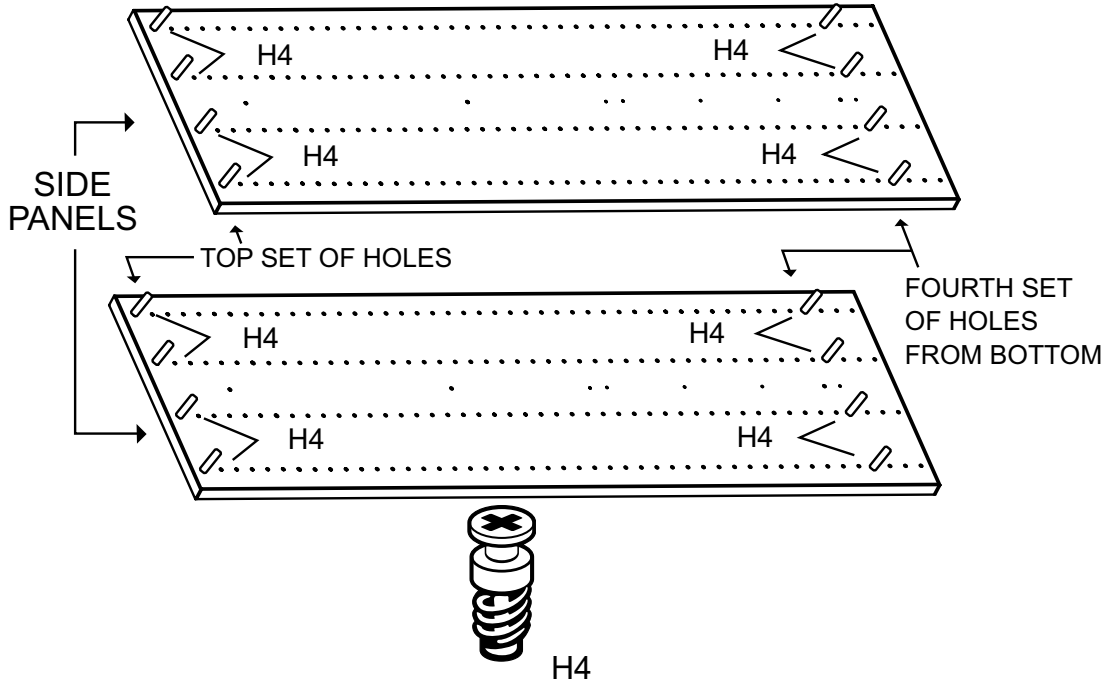

#4

For a Metal Frame, attach the Frame (H7) as shown using five #8 x 5/8" Panhead Screws.

For a 3/4" Back, follow the directions for a Back Panel. Attach the Back Panel (D) to the Side (A) as shown. Tighten the Rafix Cams (H1) 1/2 turn.

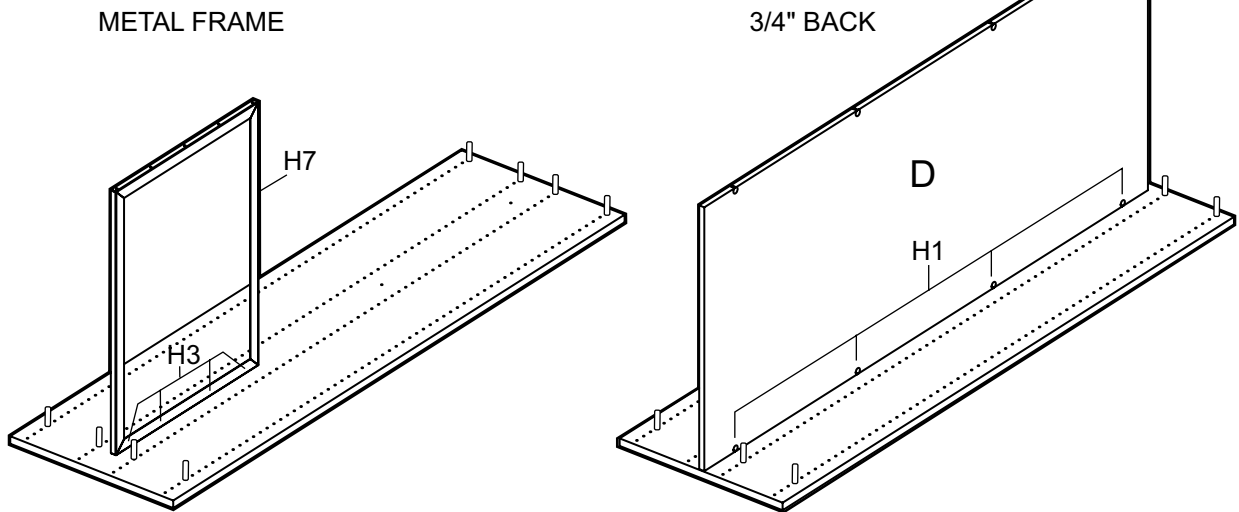

**NOTE:** If you are installing an Adder, follow the instructions for an Adder unit at this time.

#5

With the assistance of another person, stand the assembly upright and attach the other Side Panel.

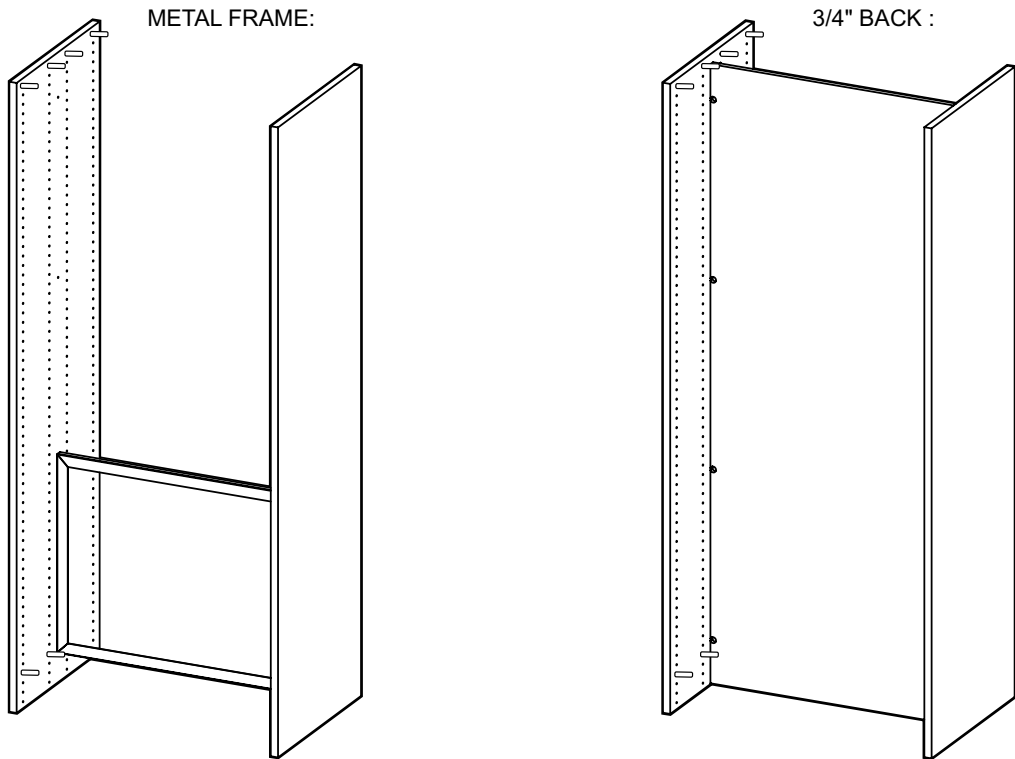

**NOTE: If you are installing the Toe Space option, it is recommended to install the Toe Space at this time. Follow the directions included with the Toe Space option.**

#6

Attach the Top Panel (C) using the Rafix System. Turn the eight Rafix Cams (H1) 1/2 turn clockwise to secure.

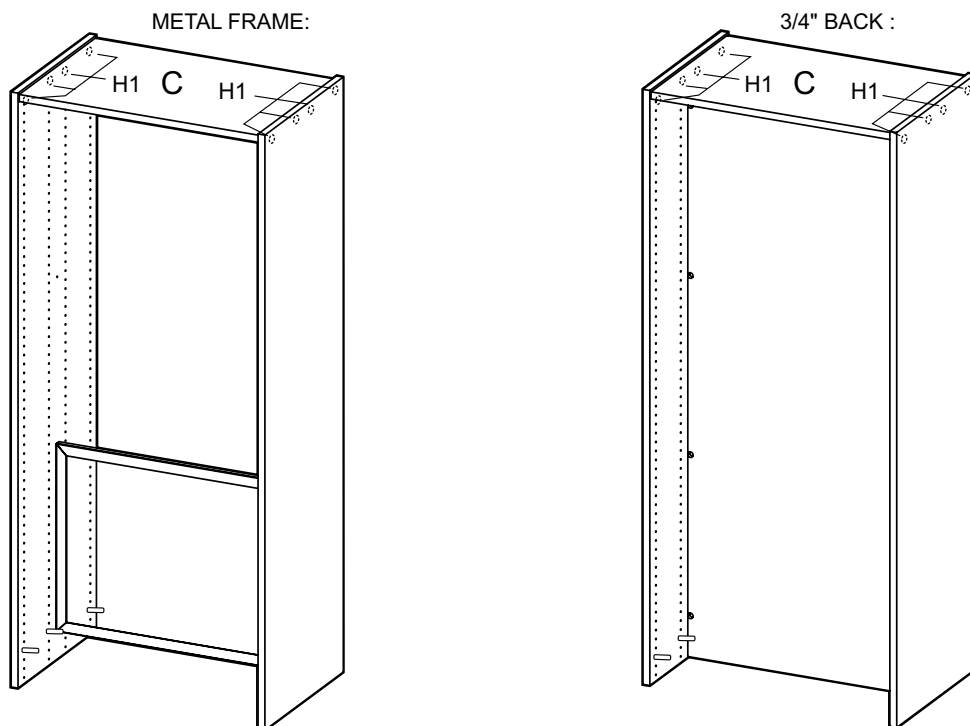

#7

Attach two Fixed Shelves (E) in the same manner.

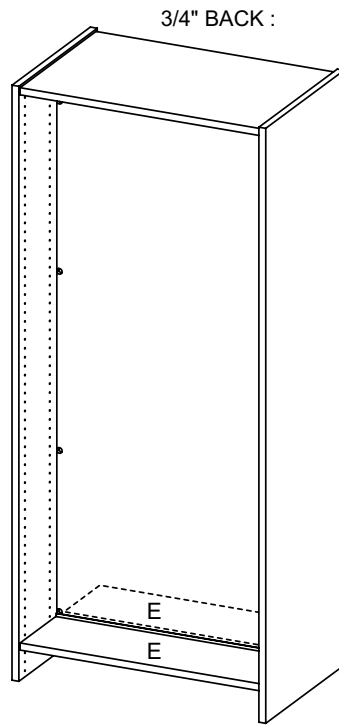
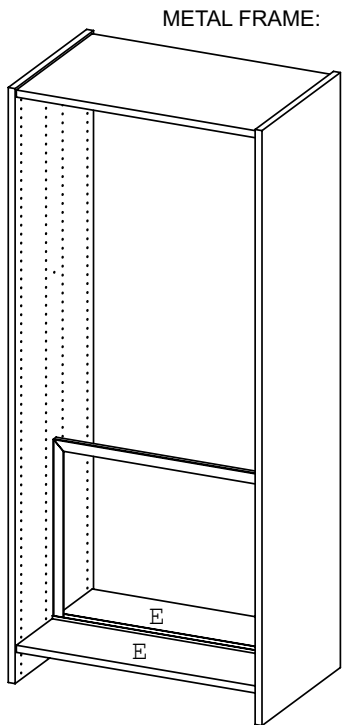

#8

Placement of the Adjustable Shelves is optional. The diagram below shows a recommended placement for the spacing of the shelves.

**NOTE:** The diagram shows the LS84DB. The shorter bookcases will use the appropriate sets of placements.

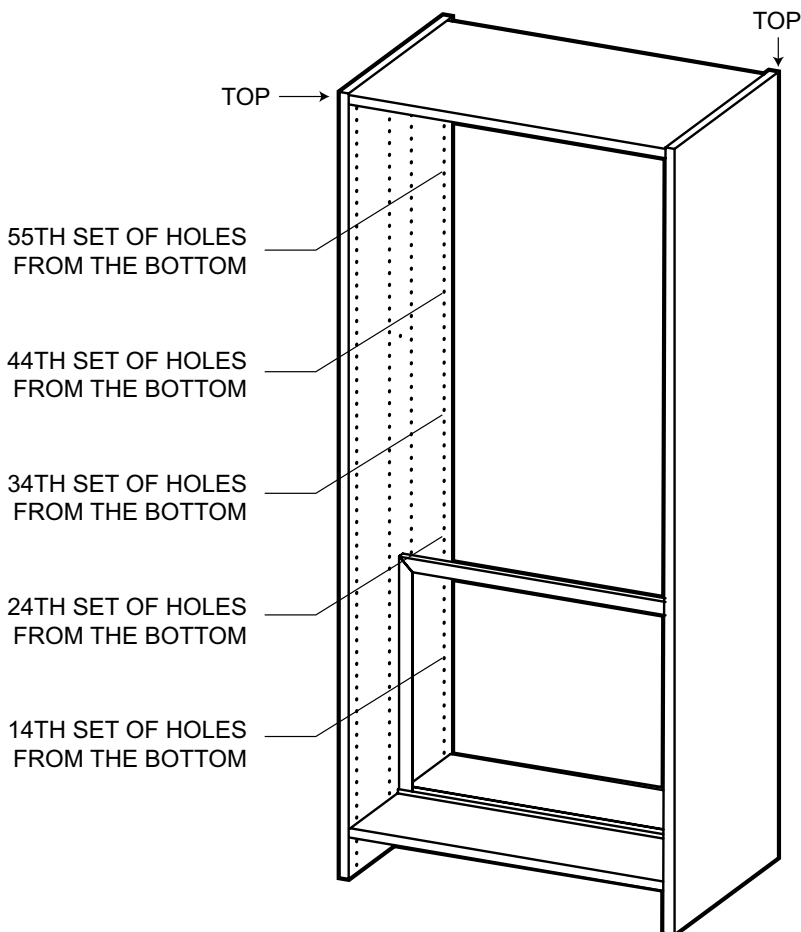



#9

Insert Rafix Shelf Pin(H6)  
into both Sides at the  
preferred heights for the  
Adjustable Shelves.

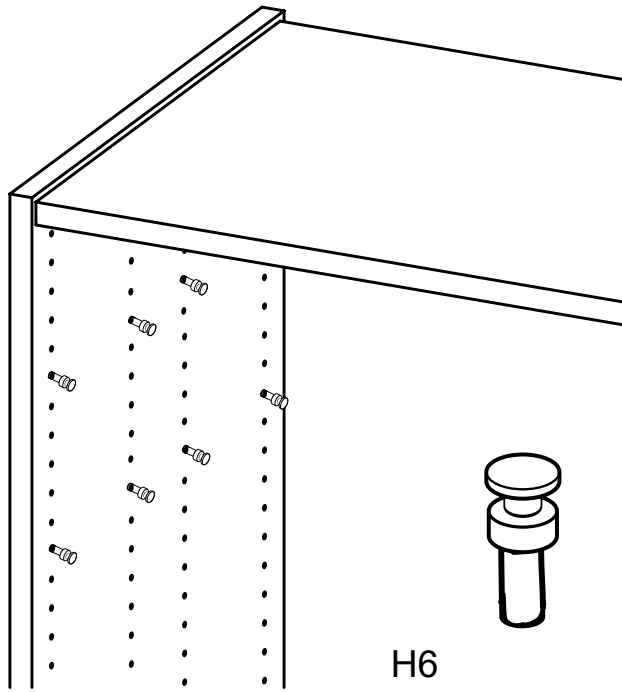

#10

Place the Adjustable  
Shelves (E) into each side  
of the unit by sliding the  
Rafix Shelf Cams(H5) in to  
Rafix Shelf Pin(H6)

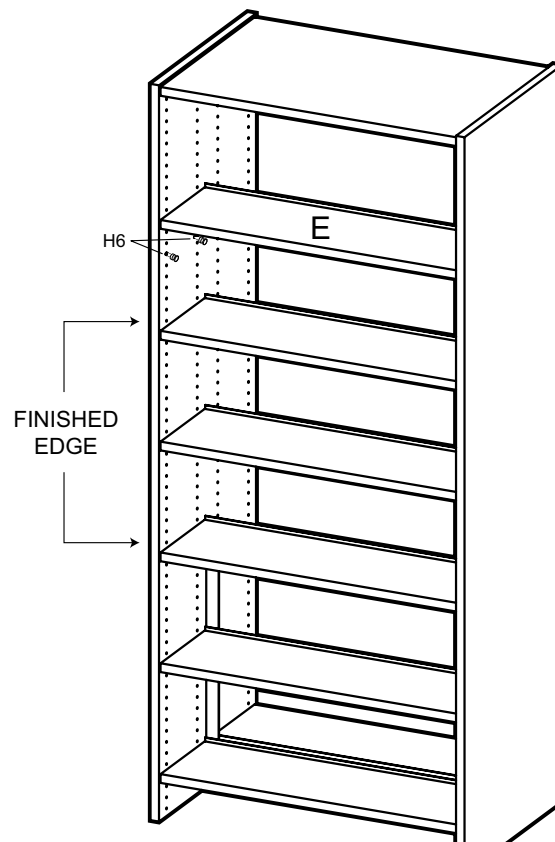

**#11**

**Your Glacier Library Shelving unit is now assembled and ready for use.**

