

LWRC

ROUND CONNECTOR

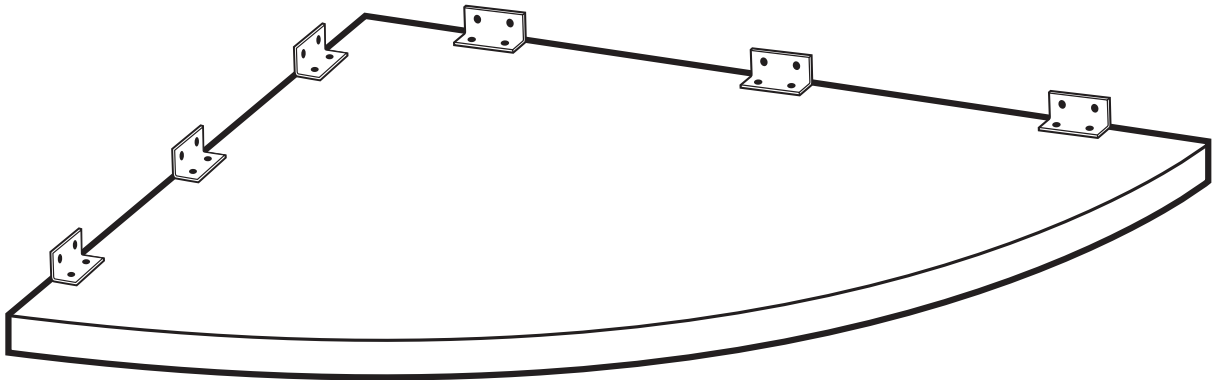

IMPORTANT!

Assembly may require the assistance of another person.

Before you begin assembly:

READ THE DIRECTIONS all the way through one time. This will speed up the process and help you understand the sequence of steps.

COUNT THE PARTS AND HARDWARE before assembly. This ensures you have received all necessary parts before you begin.

TOOLS: You may need a Phillips head screwdriver, a medium slotted screwdriver or a plastic mallet. To protect your new furniture from damage during assembly, it is recommended to work on a carpeted surface.

In the event any parts are missing from this package, send your name, address, telephone number, and a description of the missing part(s) to: PARTS, Box 1420, Missoula, MT 59806 or call: 1-800-769-5693 or FAX 1-800-445-5281.

CAUTION: On assemblies requiring glue, make sure the unit is assembled correctly before gluing. Once this unit is assembled with glue, the manufacturer will not be responsible for damaged parts. Keep a damp cloth or sponge handy to wipe off excess glue.

To care for this furniture, simply wipe with a cloth dampened with glass cleaner containing ammonia-D.

PARTS & HARDWARE

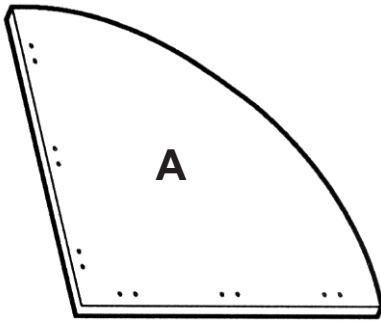

Round Connector	06002201	1 ea.
-----------------	----------	-------

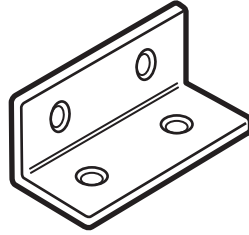

H1	Angle Bracket	1401170	6 ea.
----	---------------	---------	-------



H2	Panhead Screw	901220	12 ea.
----	---------------	--------	--------



H3	Varianta Screw	988060	12 ea.
----	----------------	--------	--------

#1

Lab Workstations may be joined using the Round Connector in the configurations shown below. Arrange the units in the chosen configuration and indicate the panels that will be drilled for the mounting brackets by marking them with your chosen method.

NOTE: Drill only the appropriate panels!

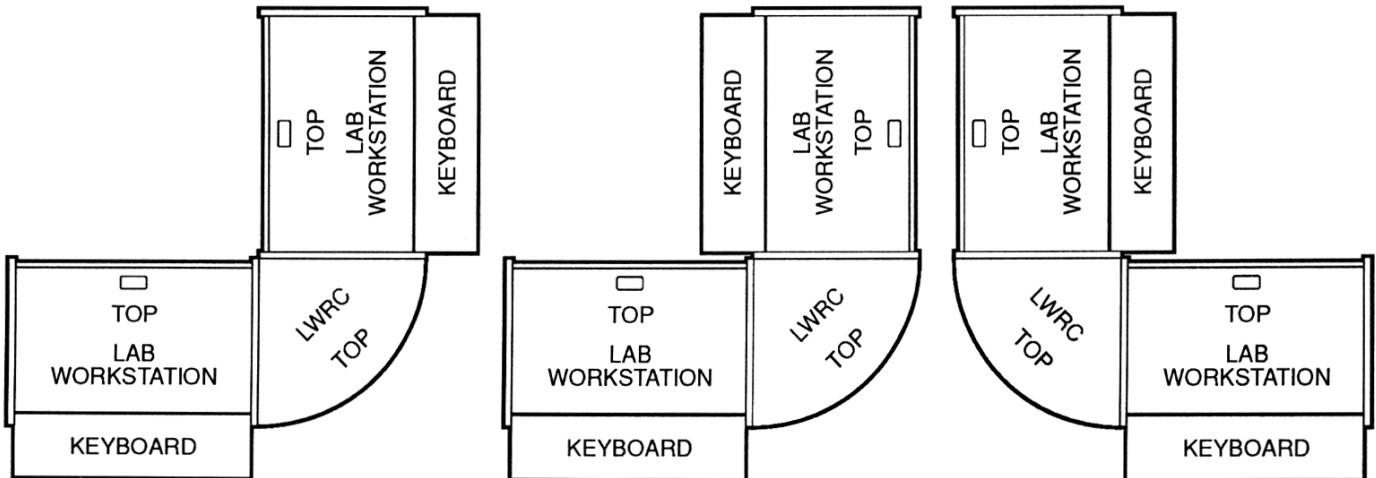

#2**#3**

See steps #2 and #3 printed on the template to mark and drill pilot holes.
NOTE: Only drill the appropriate panels!

#4

Attach three Angle Brackets (H1) to each attaching Side Panel using the Panhead Screws (H2) into the pilot holes.

NOTE: Do not tighten these screws yet.

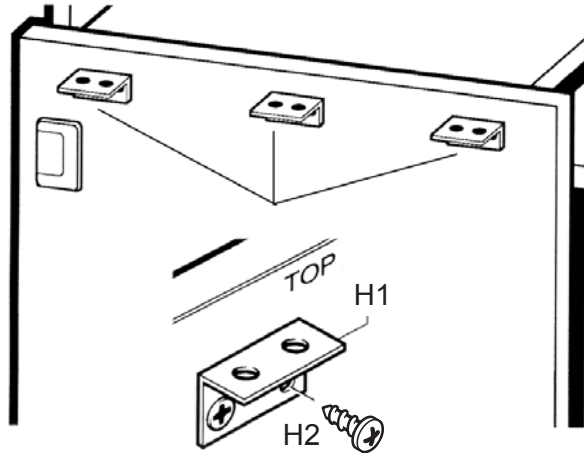
**#5**

Position the Lab Workstations together in the chosen configuration and place of use. Align the Side Panels and adjust the levelers to equalize the height if necessary.

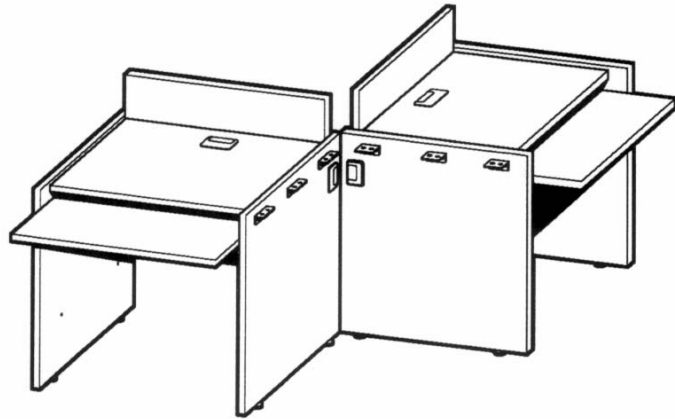
**#6**

Place the Square Connector (A) onto the Angle Brackets (H1) as shown. Secure in place using the Varianta Screws (H3) through the Angle Brackets (H1) into the pre-drilled holes in the underside of the Square Connector (A).

NOTE: Tighten all the Panhead Screws at this time.

