

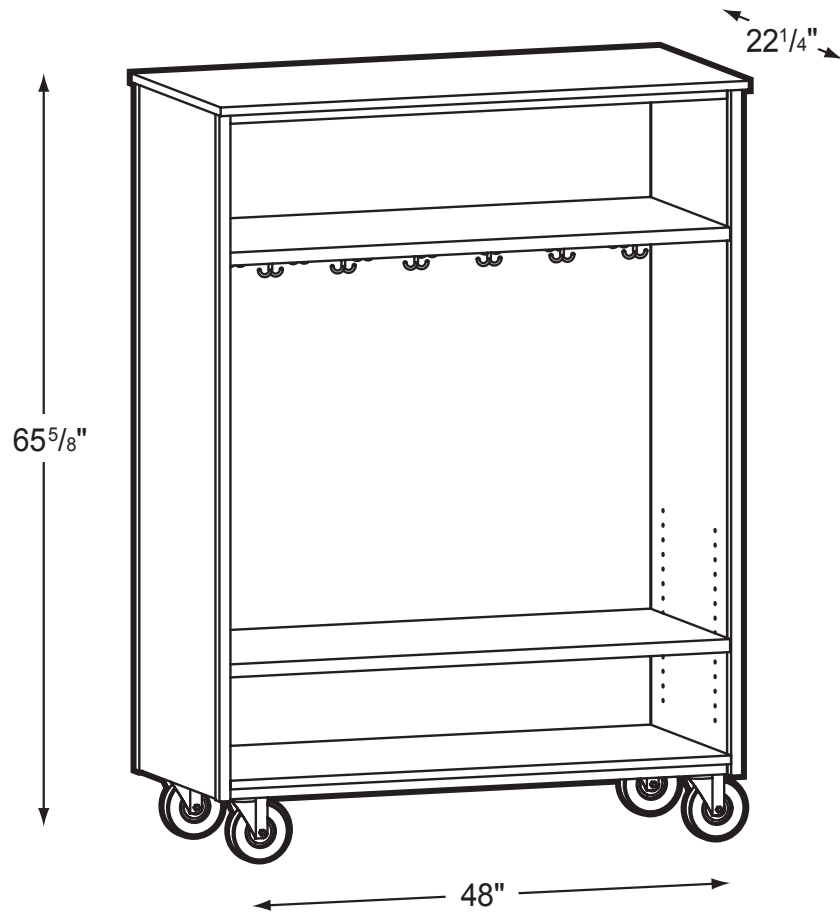

1036-O

Open-Wardrobe



Product Specs

- Fully welded unitized frame
- 10 ga. angle iron
- 3/16" caster mounting plates
- 5" casters (2 locking)
- 5mm steel shelf supports
- Cast double prong coat hook
- 3/4" thermal fused laminate
- 1" thermal fused laminate on shelves over 32".
- 3mm PVC edge banding on all semi and exposed edges.
- One adjustable shelf.
- One fixed shelf w/13 hooks