

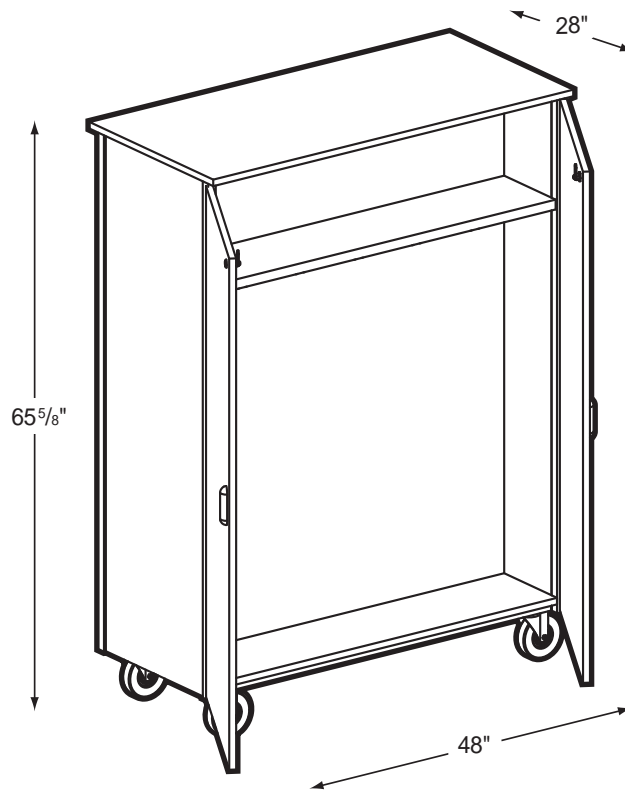

1038-CL

Closed-Double Faced Combo Unit w/Locks



Product Specs

- Fully welded unitized frame
- 10 ga. angle iron
- 3/16" caster mounting plates
- 5" casters (2 locking)
- 5mm steel shelf supports
- 5 knuckle hinges w/hospital tips
- Triple bar magnetic catch
- Hooded abs plastic four fingered pull
- Five disk cam lock
- Cast double prong coat hook
- 3/4" thermal fused laminate
- 1" thermal fused laminate on shelves over 32".
- 3mm PVC edge banding on all semi and exposed edges.
- Four adjustable shelves on one side.
- One fixed shelf w/5 hooks on one side.