



IRONWOOD
MANUFACTURING

MOBILE 1000 SERIES

1041-CL

Closed-General Storage w/Locks

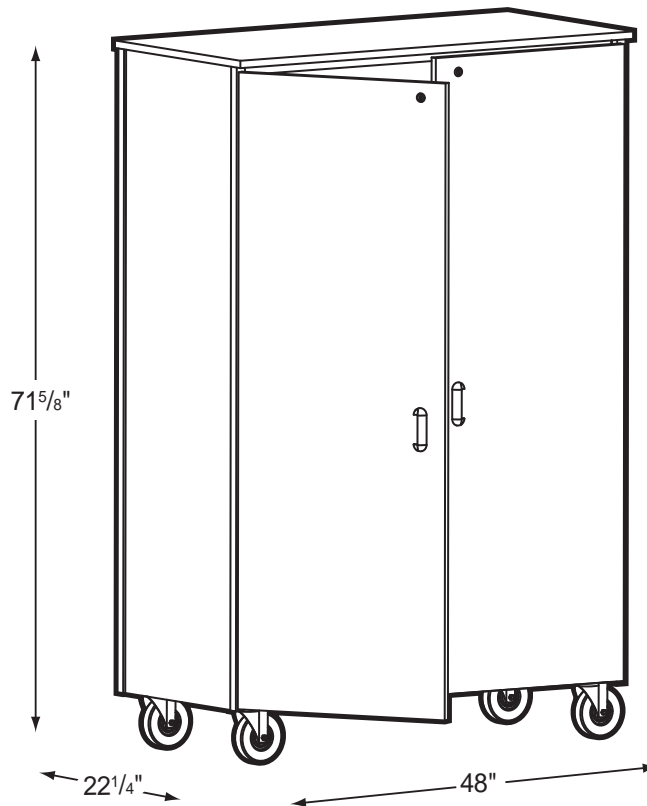

Product Specs

- Fully welded unitized frame
- 16 ga. tubing
- 10 ga. angle iron
- 3/16" caster mounting plates
- 5" casters (2 locking)
- 5mm steel shelf supports
- 5 knuckle hinges w/hospital tips
- Triple bar magnetic catch
- Hooded abs plastic four fingered pull
- Five disk cam lock
- 3/4" thermal fused laminate
- 1" thermal fused laminate on shelves over 32.
- 3mm PVC edge banding on all semi and exposed edges
- Four adjustable shelves
- One fixed shelf

0208