



**IRONWOOD**  
MANUFACTURING

MOBILE 1000 SERIES

# 1042-CL

## Closed-Cubical Storage w/Locks

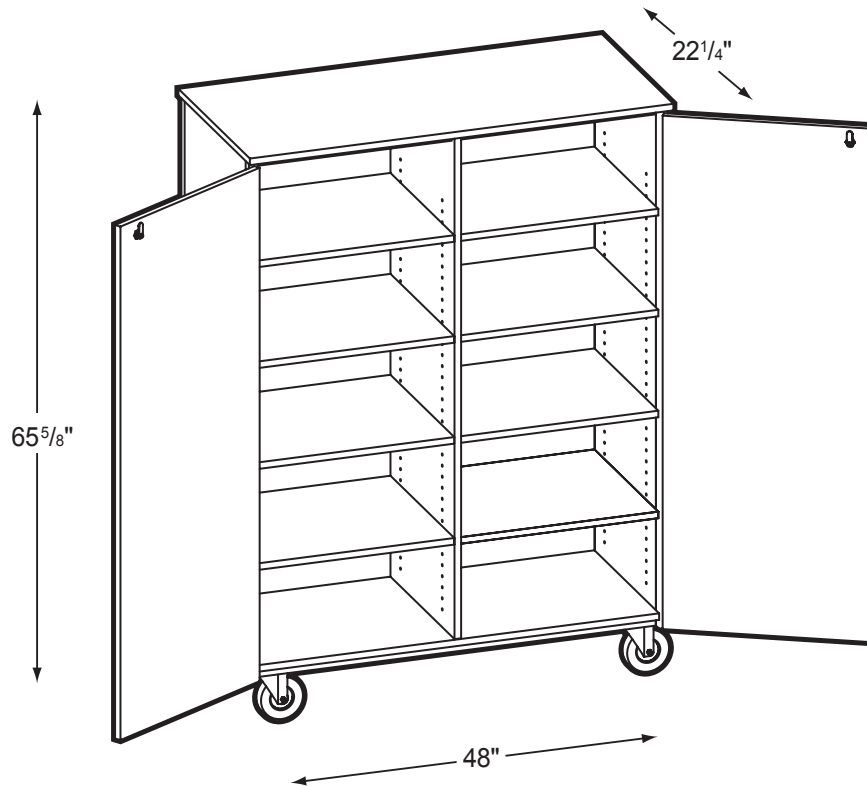

### Product Specs

- Fully welded unitized frame
- 10 ga. angle iron
- 3/16" caster mounting plates
- 5" casters (2 locking)
- 5mm steel shelf supports
- 5 knuckle hinges w/hospital tips
- Triple bar magnetic catch
- Hooded abs plastic four fingered pull
- Five disk cam lock
- 3/4" thermal fused laminate
- 1" thermal fused laminate on shelves over 32"
- 3mm PVC edge banding on all semi and exposed edges
- Eight 1/2" width adjustable shelves

0309

Ironwood Manufacturing • P.O. Box 1420 • Missoula, Montana 59806  
(406) 721-4747 • (800) 769-5693 • fax (406) 721-8424 • [www.ironwoodmfg.com](http://www.ironwoodmfg.com)