



**IRONWOOD**  
MANUFACTURING

MOBILE 1000 SERIES

# 1054-O

## Open-Combination Storage

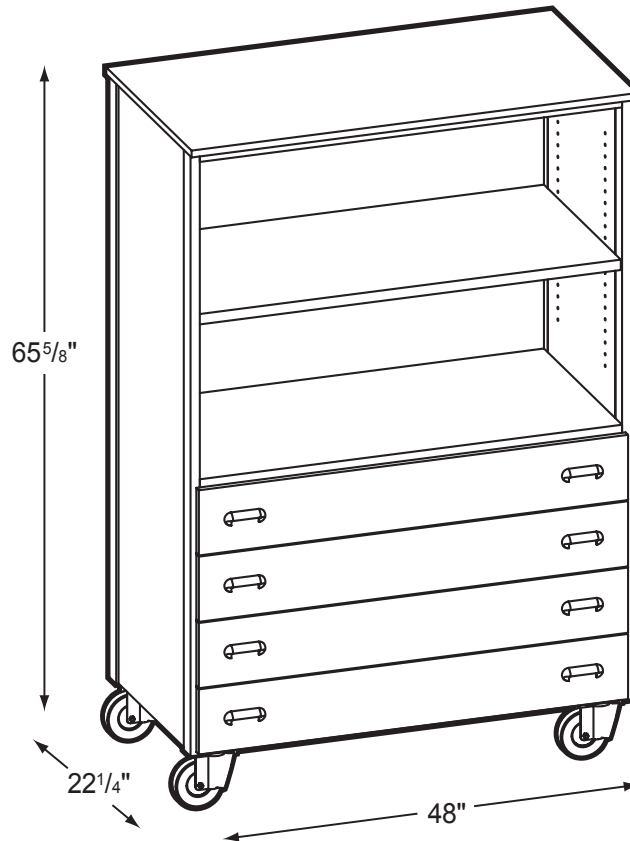

### Product Specs

- Fully welded unitized frame
- 10 ga. angle iron
- 3/16" caster mounting plates
- 5" casters (2 locking)
- 5mm steel shelf supports
- 100# rated 2/3 extension drawer slide w/lock
- Hooded abs plastic four fingered pull
- 3/4" thermal fused laminate
- 1" thermal fused laminate on shelves over 32"
- 3mm PVC edge banding on all semi and exposed edges
- One adjustable shelf
- Four full width drawers

0309