



IRONWOOD
MANUFACTURING

MOBILE 1000 SERIES

1055-0

Open-Combination Storage

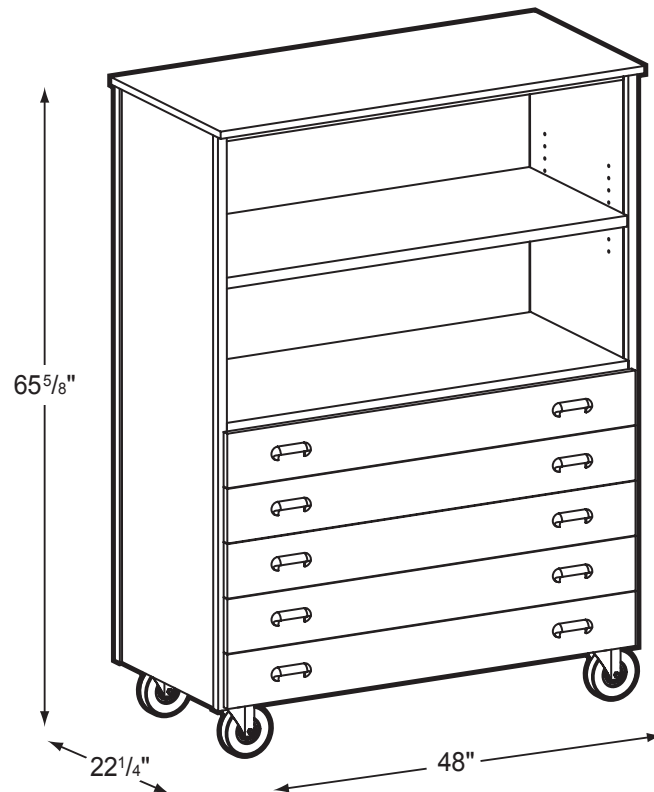

Product Specs

- Fully welded unitized frame
- 10 ga. angle iron
- 3/16" caster mounting plates
- 5" casters (2 locking)
- 5mm steel shelf supports
- 100# rated 2/3 extension drawer slide w/lock
- Hooded abs plastic four fingered pull
- 3/4" thermal fused laminate
- 3mm PVC edge banding on all semi and exposed edges
- One adjustable shelf
- Five full width drawers

0309