



IRONWOOD
MANUFACTURING

MOBILE 1000 SERIES

1062-0

Open-Double Faced Bookcase

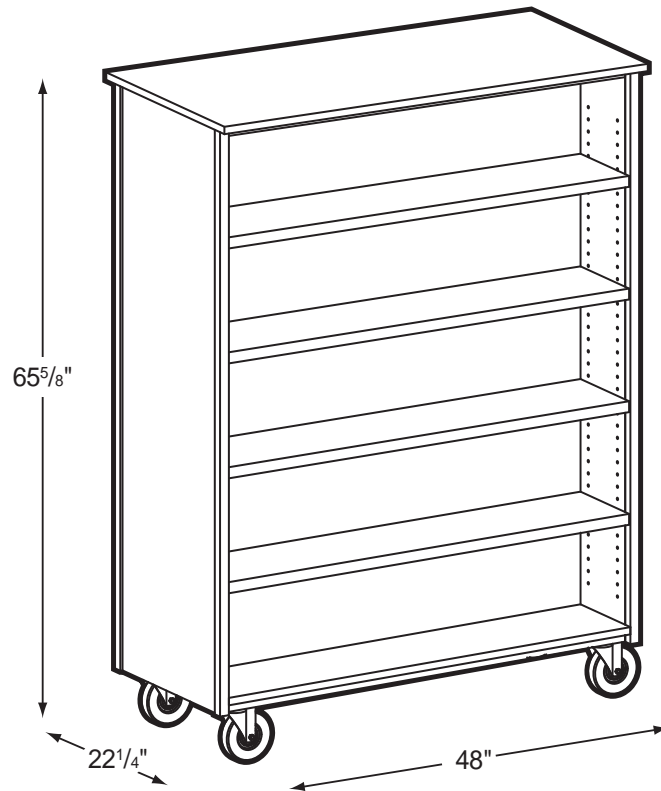

Product Specs

- Fully welded unitized frame
- 10 ga. angle iron
- 3/16" caster mounting plates
- 5" casters (2 locking)
- 5mm steel shelf supports
- 3/4" thermal fused laminate
- 1" thermal fused laminate on shelves over 32".
- 3mm PVC edge banding on all semi and exposed edges.
- Four adjustable shelves on each side.

0212