



**MODULAR SERIES 2400  
OFFICE FURNITURE**

---

# **MPNF72**

---

## **FREE STANDING PENINSULA**

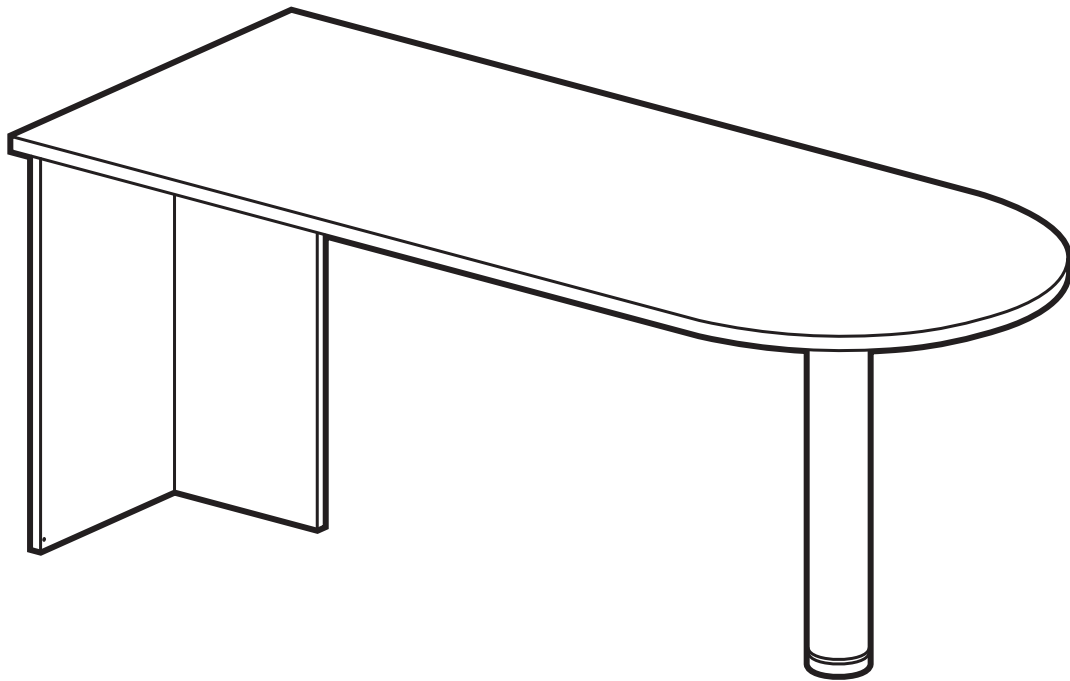

### **IMPORTANT!**

**Assembly may require the assistance of another person.**

**Before you begin assembly:**

**READ THE DIRECTIONS** all the way through one time. This will speed up the process and help you understand the sequence of steps.

**COUNT THE PARTS AND HARDWARE** before assembly. This ensures you have received all necessary parts before you begin.

**TOOLS:** You may need a Phillips head screwdriver, a medium slotted screwdriver or a plastic mallet. To protect your new furniture from damage during assembly, it is recommended to work on a carpeted surface.

In the event any parts are missing from this package, send your name, address, telephone number, and a description of the missing part(s) to: **PARTS, Box 1420, Missoula, MT 59806** or call: **1-800-769-5693** or **FAX 1-800-445-5281**.

**CAUTION:** On assemblies requiring glue, make sure the unit is assembled correctly before gluing. Once this unit is assembled with glue, the manufacturer will not be responsible for damaged parts. Keep a damp cloth or sponge handy to wipe off excess glue.

To care for this furniture, simply wipe with a cloth dampened with glass cleaner containing ammonia-D.

# PARTS DIAGRAM



Leg	300770	1 ea.
-----	--------	-------

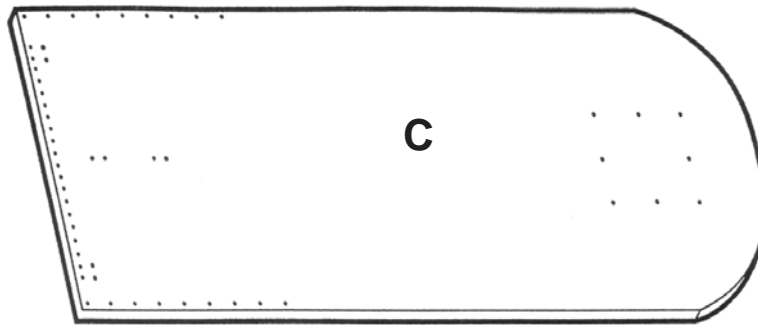

Top Panel	02330201	1 ea.
-----------	----------	-------

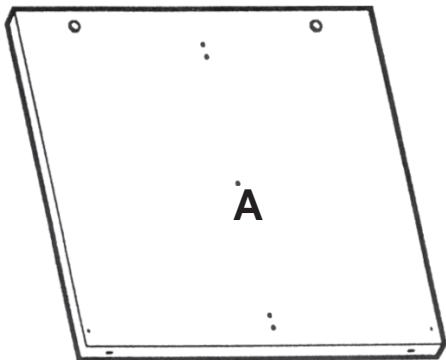

End Panel	02330241	1 ea.
-----------	----------	-------

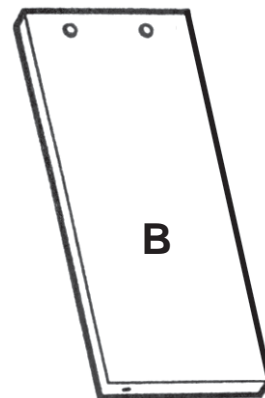

Support Panel	02330298	1 ea.
---------------	----------	-------



H1	Minifix Bolt	909834	7
----	--------------	--------	---



H4	Leveler Insert	274650	3
----	----------------	--------	---



H3	Minifix Cam	909810	7
----	-------------	--------	---

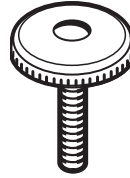

H6	Leveler	300870	3
----	---------	--------	---



H5	Leveler Bracket	402303	3
----	-----------------	--------	---



H10	#10 x 3/4" Panhead Screw	H2030	8
-----	-----------------------------	-------	---



H2	Wood Dowel	195000	6
----	------------	--------	---

### Using the Minifix System:

Insert the Minifix Cams into the appropriate holes with the arrow facing outwards as shown

When screwing fast into hole **Do Not** overtighten. Screw fast down until bottom face of fast flange just touches board surface

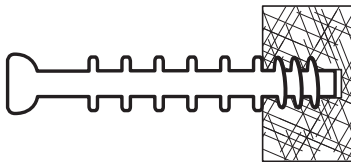

Using the #2 Phillips screwdriver rotate the Cam Devices a half turn clockwise until snappy

To disassemble turn the Cam Devices counter-clockwise and remove panels

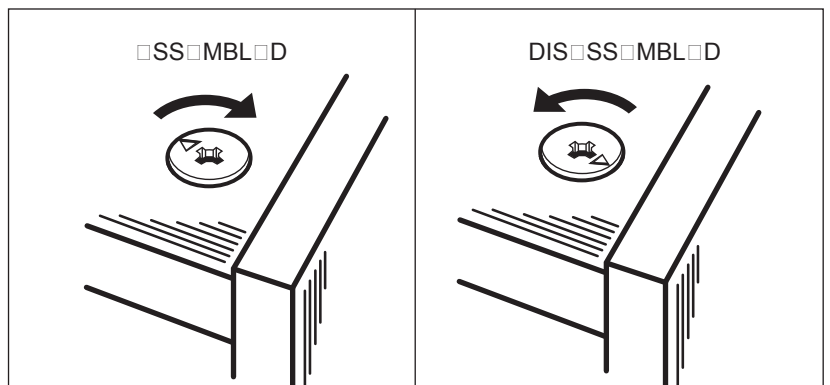
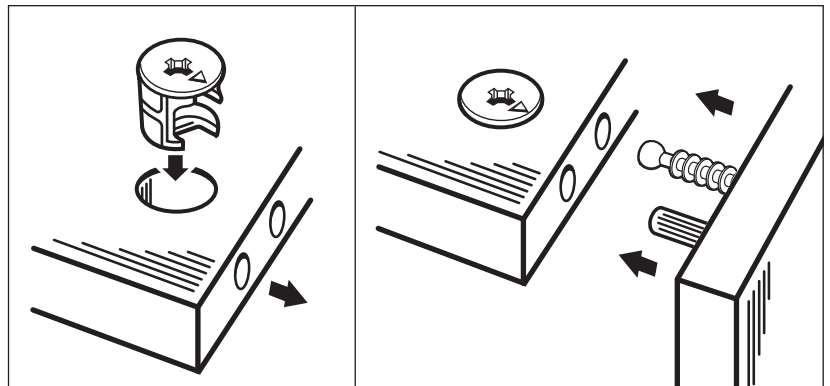

**#1**

Place the Top Panel (C) on a clean, carpeted surface or foam padding with the pre-drilled holes facing up. Using a screwdriver, screw four Minifix Bolts (H1) into the Top Panel where indicated.

Insert four Wood Dowels (H2) into the Top Panel where indicated.

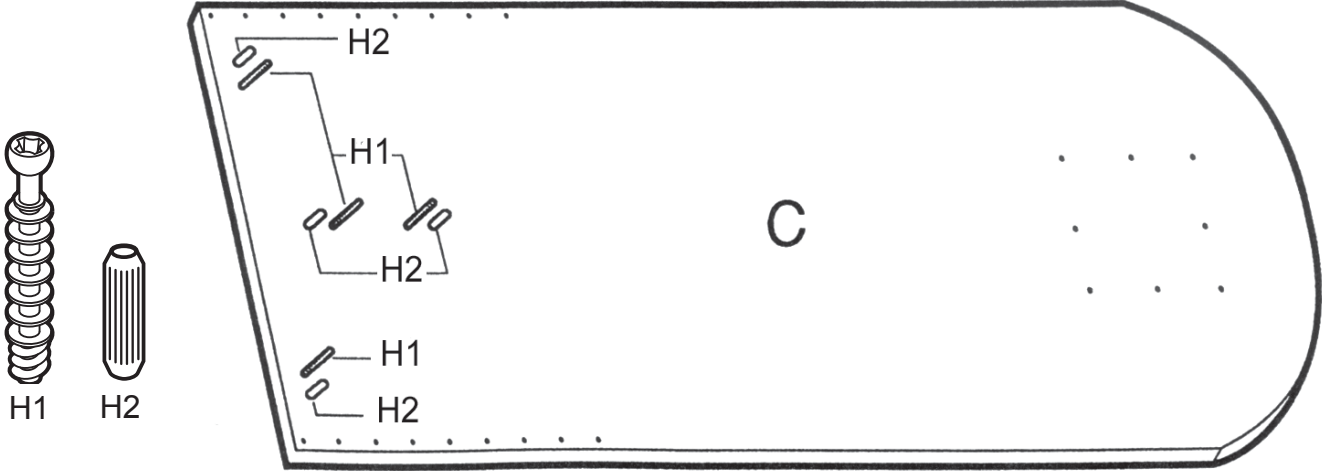

**#2**

Insert two Minifix Cams (H3) into the End Panel (A) with the arrows of the cams facing out. Insert two Wood Dowels (H2) into the End Panel where indicated. Screw three Minifix Bolts (H1) into the End Panel where indicated.

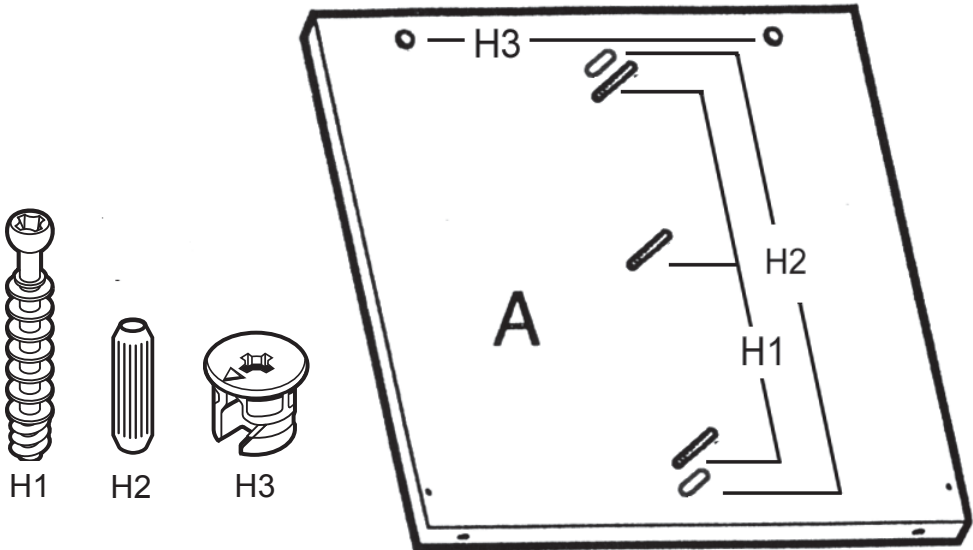

### #3

Insert five Minifix Cams (H3) into the Support Panel (B) with the arrows of the cams facing out.

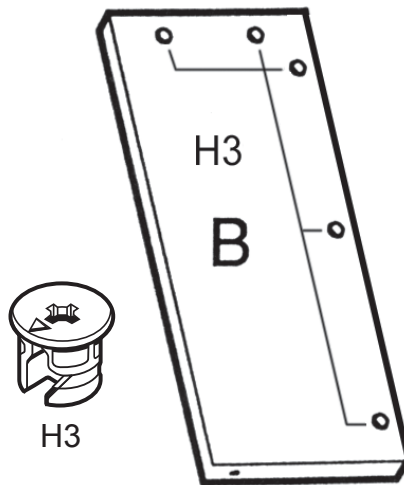

### #4

Insert the Leveler Inserts (H4) into the holes in the bottom edges of the End Panel (A) and the Support Panel (B). Using a plastic mallet, tap Leveler Inserts until flush with the surface. Press a Leveler Bracket (H5) over each Leveler Insert. Screw the Levelers (H6) into the Leveler Inserts. Adjust Levelers when the assembled unit is in place.

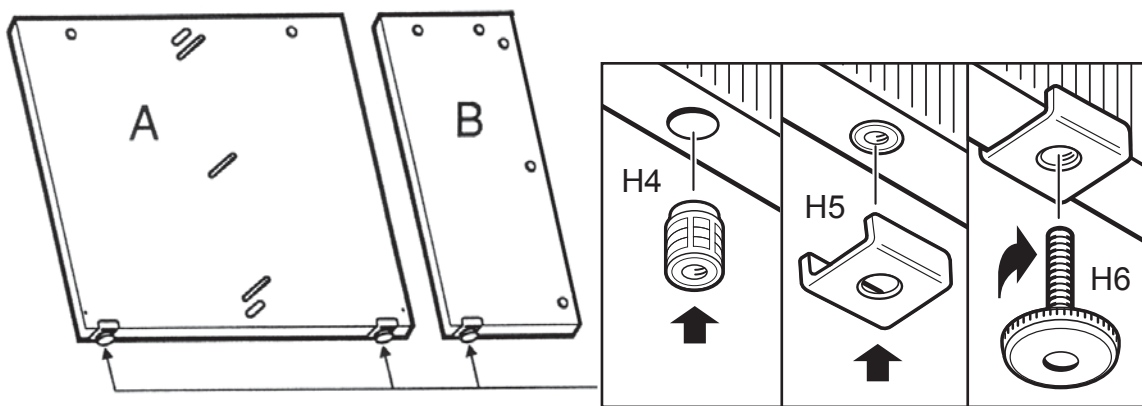

### #5

Position the Support Panel (B) onto the posts of the End Panel (A) as shown. Turn the Minifix Cams (H3) clockwise to secure in place.

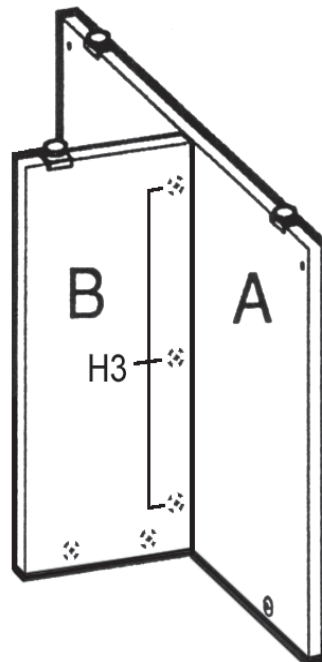

#6

Position the Support Assembly (A & B) onto the bolts and dowels of the Top Panel (C) and turn the Minifix Cams (H3) clockwise to secure.

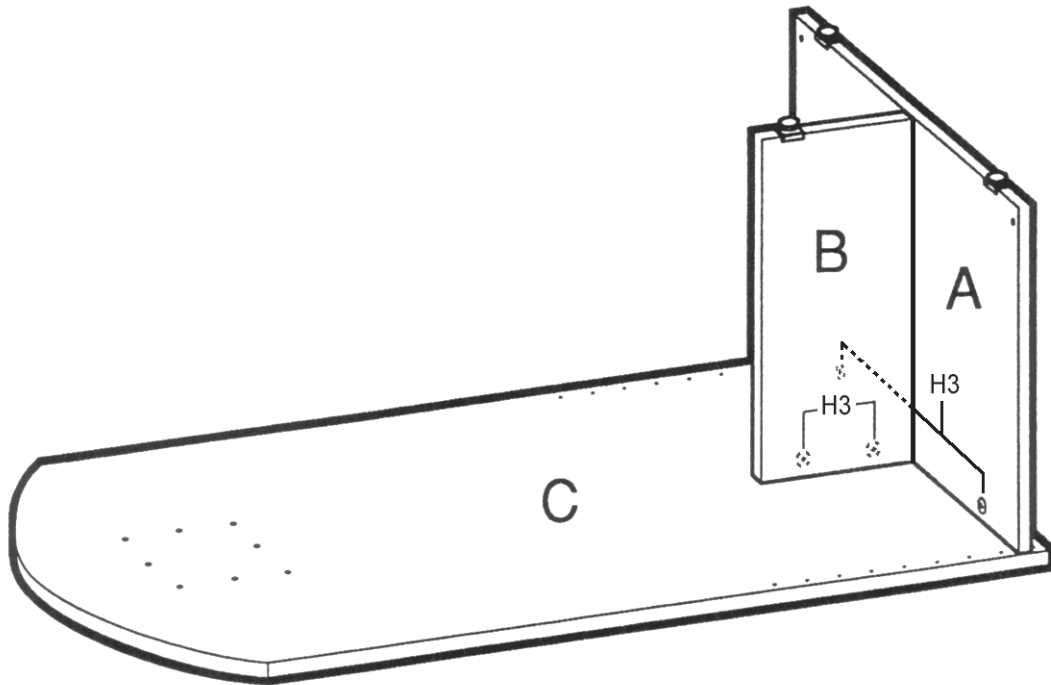

#7

Attach the Leg assembly to the Top Panel (C) using eight #10 x 3/4" Panhead Screws (H10) into the pre-drilled holes of the Top Panel.

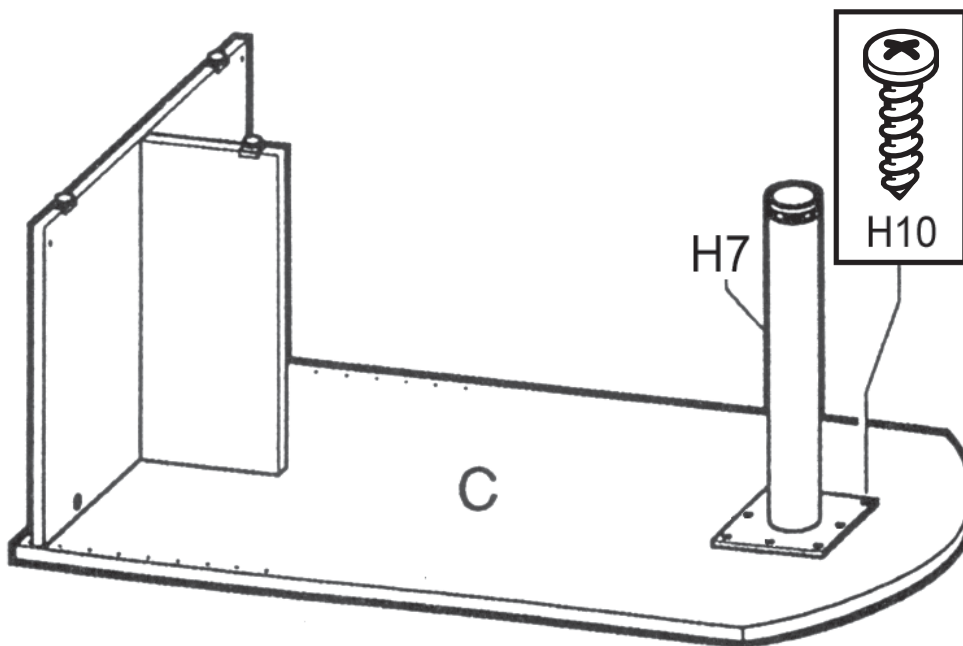

#8

With the assistance of another person, turn the unit upright. When the unit is in place, adjust the work surface to level by turning the rotating bottom portion of the support Leg.

**Assembly is now complete.**

