

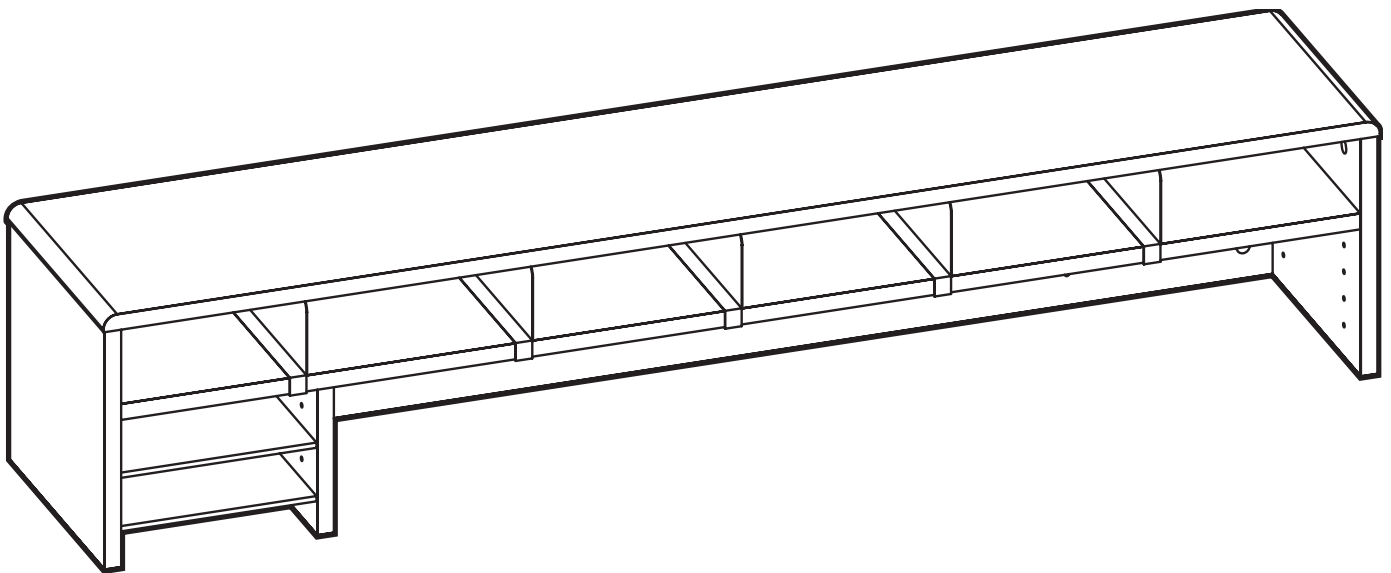

DESKTOP ORGANIZERS

DTO-LP



IMPORTANT!

Assembly may require the assistance of another person.

Before you begin assembly:

READ THE DIRECTIONS all the way through one time. This will speed up the process and help you understand the sequence of steps.

COUNT THE PARTS AND HARDWARE before assembly. This ensures you have received all necessary parts before you begin.

TOOLS: You may need a Phillips head screwdriver, a medium slotted screwdriver or a plastic mallet. To protect your new furniture from damage during assembly, it is recommended to work on a carpeted surface.

In the event any parts are missing from this package, send your name, address, telephone number, and a description of the missing part(s) to: PARTS, Box 1420, Missoula, MT 59806 or call: 1-800-769-5693 or FAX 1-800-445-5281.

CAUTION: On assemblies requiring glue, make sure the unit is assembled correctly before gluing. Once this unit is assembled with glue, the manufacturer will not be responsible for damaged parts. Keep a damp cloth or sponge handy to wipe off excess glue.

To care for this furniture, simply wipe with a cloth dampened with glass cleaner containing ammonia-D.

PARTS DIAGRAM

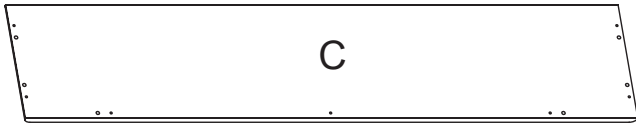

Top	05761601	1 ea.
-----	----------	-------



Fixed Shelf	05761621	1 ea.
-------------	----------	-------

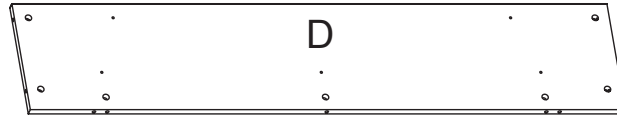

Back	05761652	1 ea.
------	----------	-------

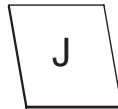

Adjustable Shelf	191670	2 ea.
------------------	--------	-------



Divider Panel	05761644	1 ea.
---------------	----------	-------

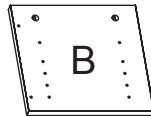

Right Side	05761642	1 ea.
------------	----------	-------

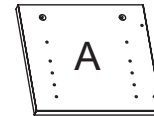

Left Side	05761642	1 ea.
-----------	----------	-------

HARDWARE



H1	Minifix Cam	909810	18 ea.
----	-------------	--------	--------



H2	Minifix Bolt	909934	18 ea.
----	--------------	--------	--------



H3	Dowel	195000	6 ea.
----	-------	--------	-------



H4	Rafix Cam	909910	3 ea.
----	-----------	--------	-------



H5	Rafix Bolt	909923	3 ea.
----	------------	--------	-------



H6	Shelf Support Pin	297210	8 ea.
----	-------------------	--------	-------



H7	Plastic Label Holders	H3404	2 ea.
----	-----------------------	-------	-------

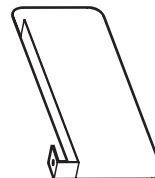

H8	Metal Shelf Dividers	H10100	5 ea.
----	----------------------	--------	-------

Using the Rafx System:

Insert the Rafx Cams into the appropriate holes. The flat edge of the cam should be facing the edge of the panel.

Slide Rafx Cams of the panel to be attached onto the corresponding posts.

When screwing post into hole, **Do Not** over tighten. Screw post down until bottom face of post flange just touches board surface.

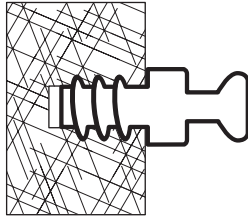

Using a #3 Phillips screwdriver, turn the rotating portion of the Rafx Cam a 1/2 turn clockwise to secure. **IMPORTANT!** Do not exceed 1/2 turn when tightening cams. Turn 1/2 turn counterclockwise to disassemble and remove panel.

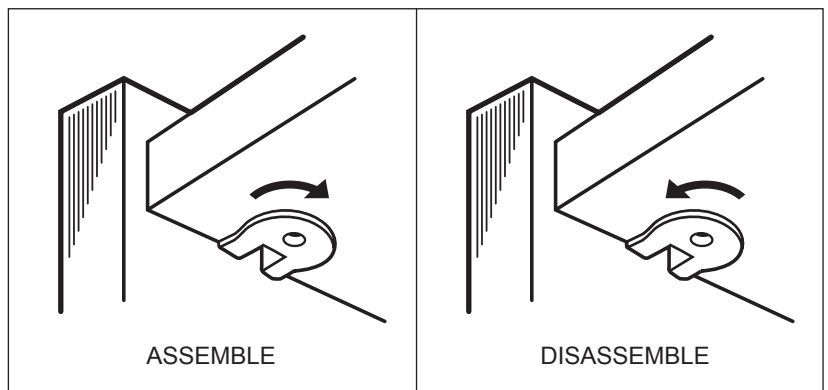
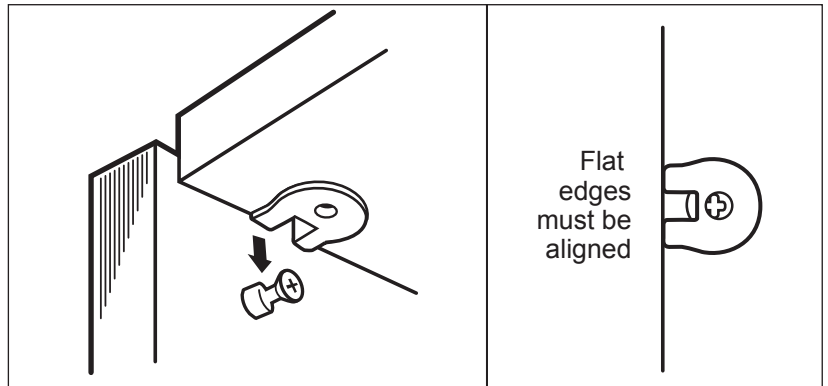

Using the Minifix System:

Insert the Minifix Cams into the appropriate holes with the arrow facing outwards as shown.

When screwing post into hole, **Do Not** over tighten. Screw post down until bottom face of post flange just touches board surface.

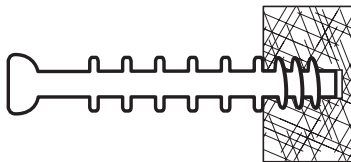

Using the #2 Phillips screwdriver, rotate the Cam Devices a half turn clockwise until snug.

To disassemble, turn the Cam Devices counter-clockwise and remove panels.

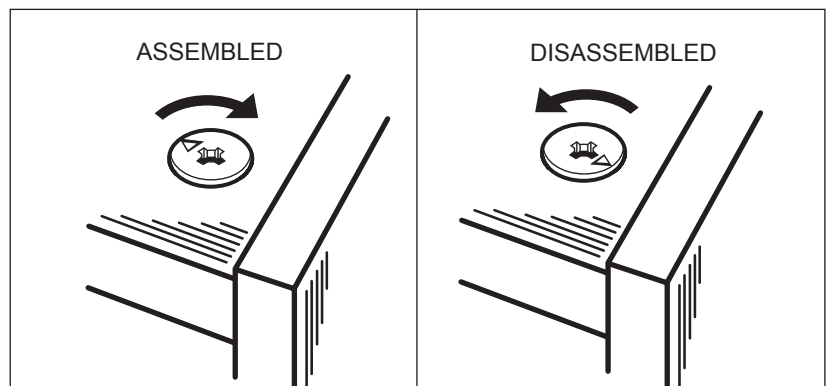
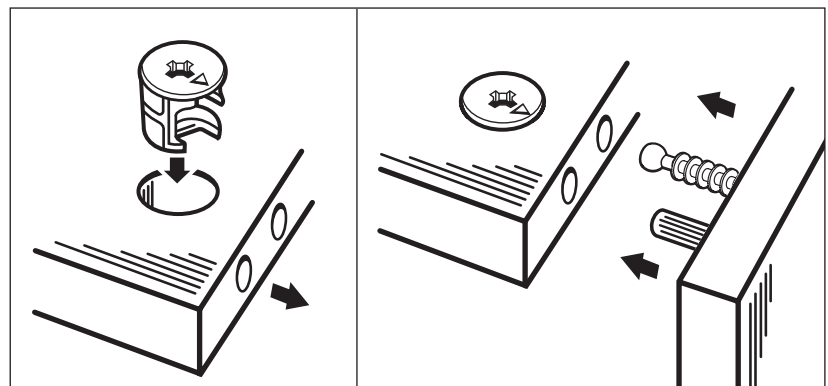

#1

Insert 7 Minifix Cams (H1) into cam holes on Back (D) and 7 Minifix Cams into the Fixed Shelf (G) so that the arrows are facing out. Screw in 3 Minifix Bolts (H2) in the Back Panel as shown.

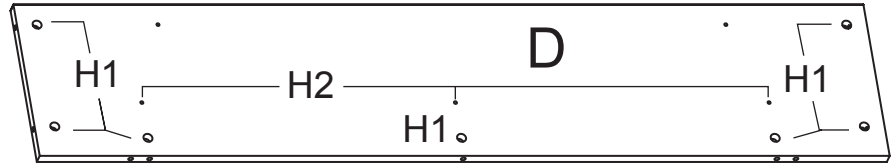
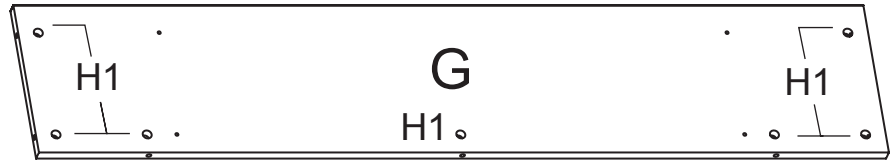

#2

Screw in 7 Minifix Bolts (H2) into top (C). Insert 6 Wood Dowels (H3) following the diagram for placement of each.

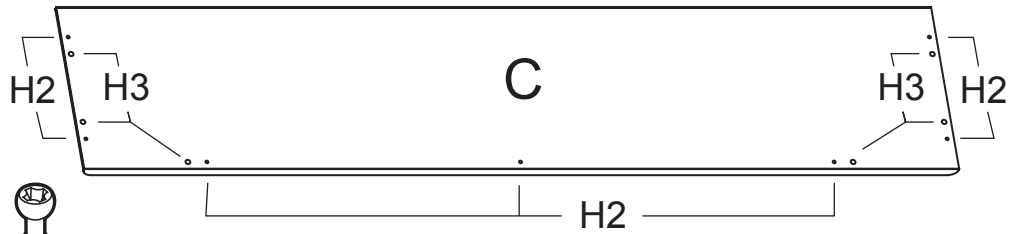

#3

Insert 2 Minifix Cams (H1) into each side (A & B). Screw in four Minifix Bolts (H2) in each side as shown.

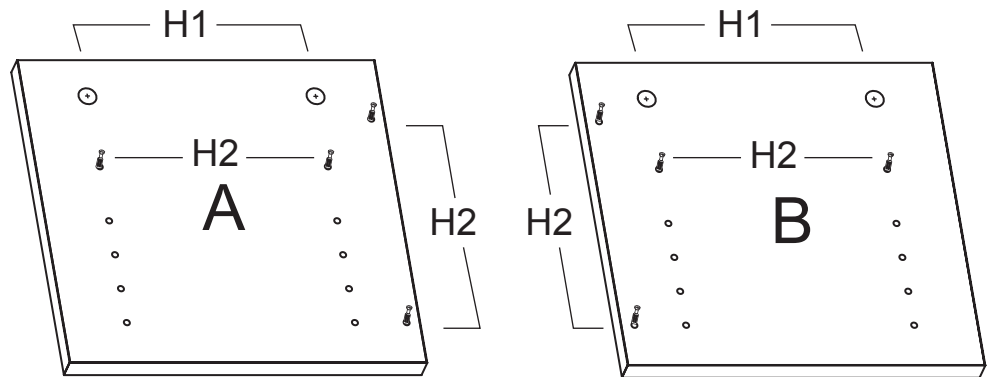

#4

Insert 3 Rafix Housings (H4) into Partition (E). Tap Rafix Housing until fully seated.

NOTE: Position as shown, Rafix Housings cannot be repositioned if installed incorrectly.

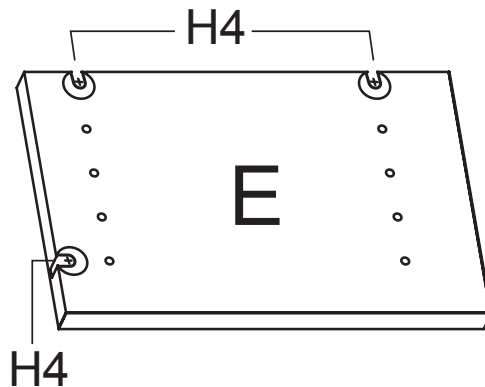

#5

Position Fixed Shelf (G) onto Back (D) as shown. Turn connecting Minifix Cams (H1) clockwise to secure.

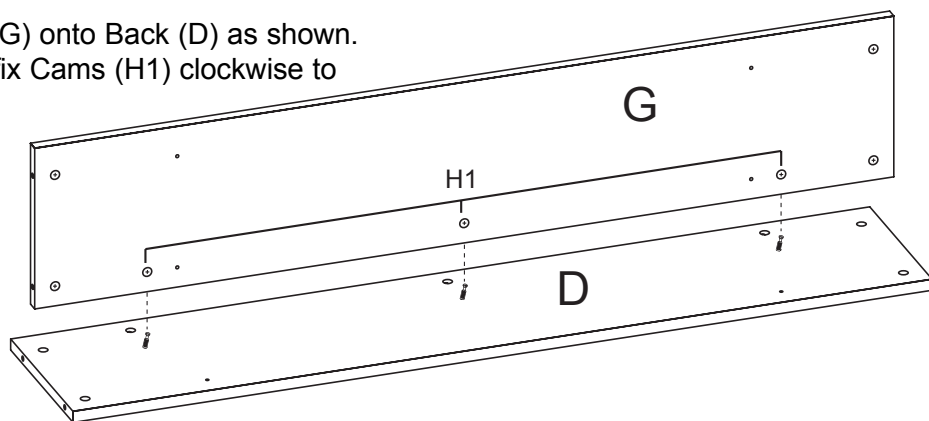
**#6**

Screw in 3 Rafix bolts (H5) in either the Left side or Right side as shown in the diagram. Slide Partition (E) into place over the Rafix Bolts and secure by turning clockwise 1/2 turn.

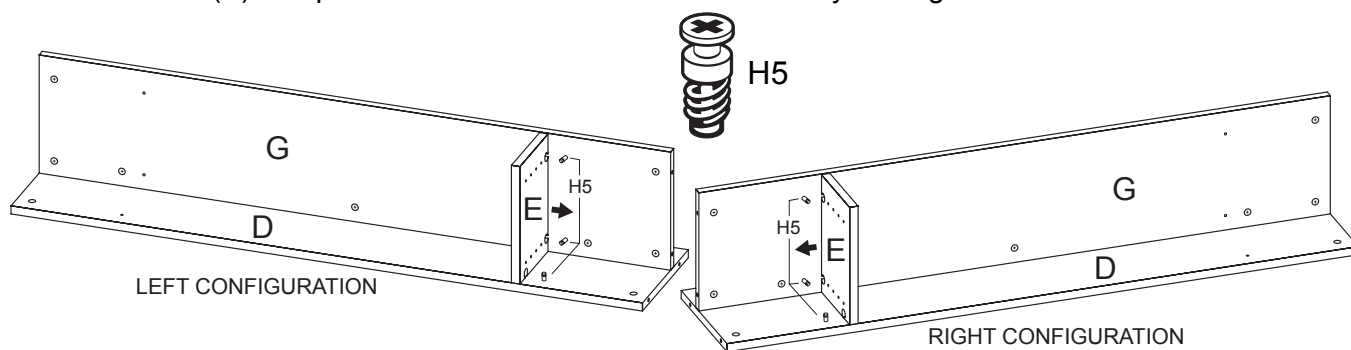
**#7**

Insert Right Side (B) or Left Side (A) onto Back (D) as shown. Turn the connecting Minifix Cams on the Back clockwise to secure.

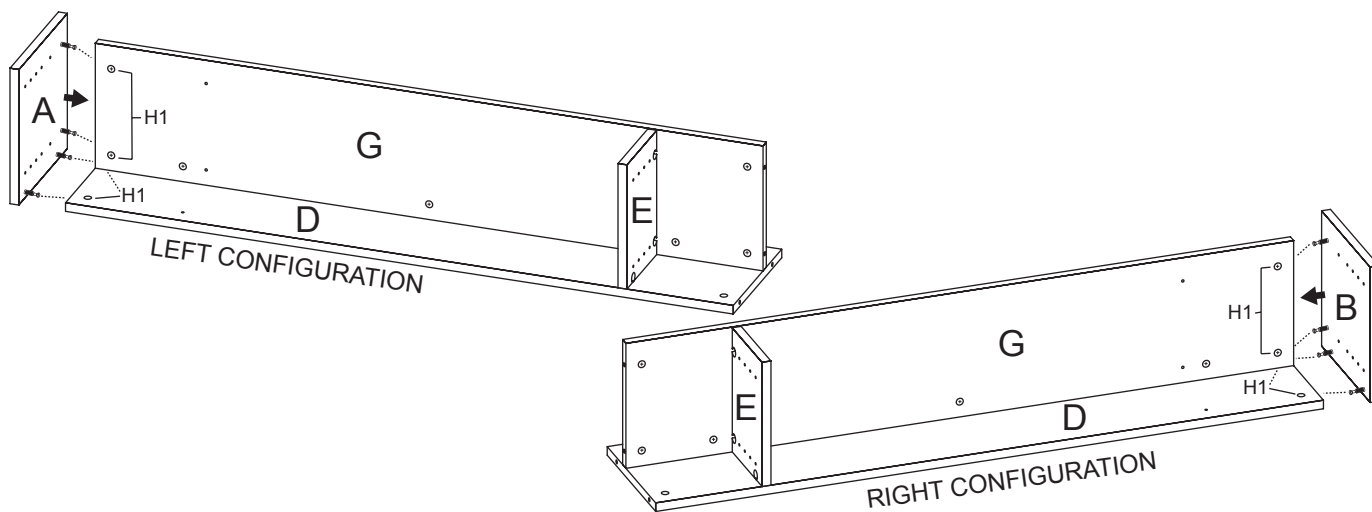

#8

Insert Left Side (A) or Right Side (B) onto Back (D) as shown. Turn the connecting Minifix Cams on the Back clockwise to secure.

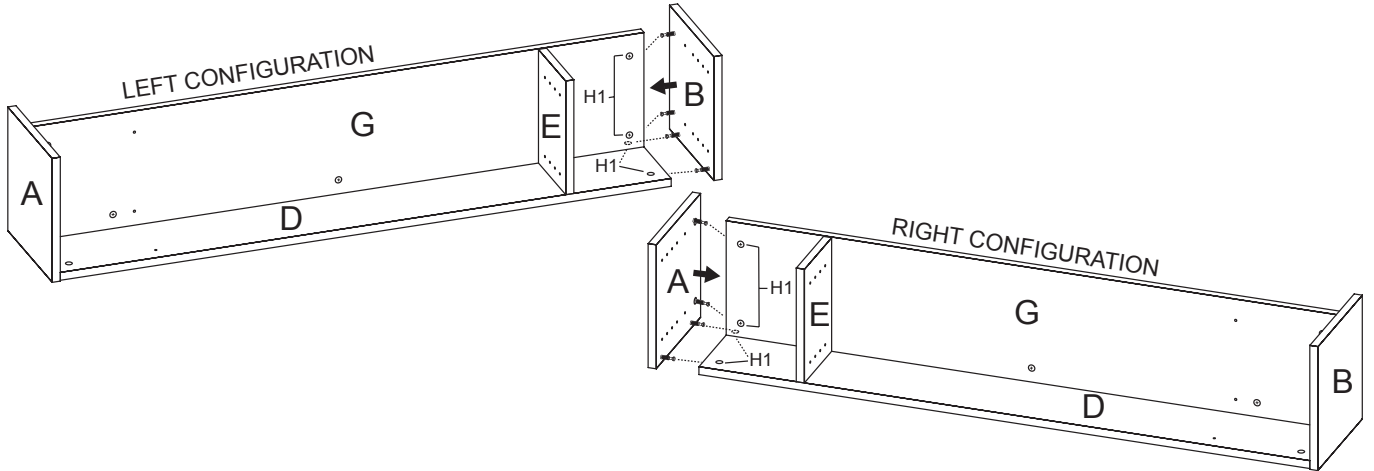
**#9**

Set the unit upright. Position Top (C) onto unit. Secure by turning the 7 connection Minifix Cams clockwise.

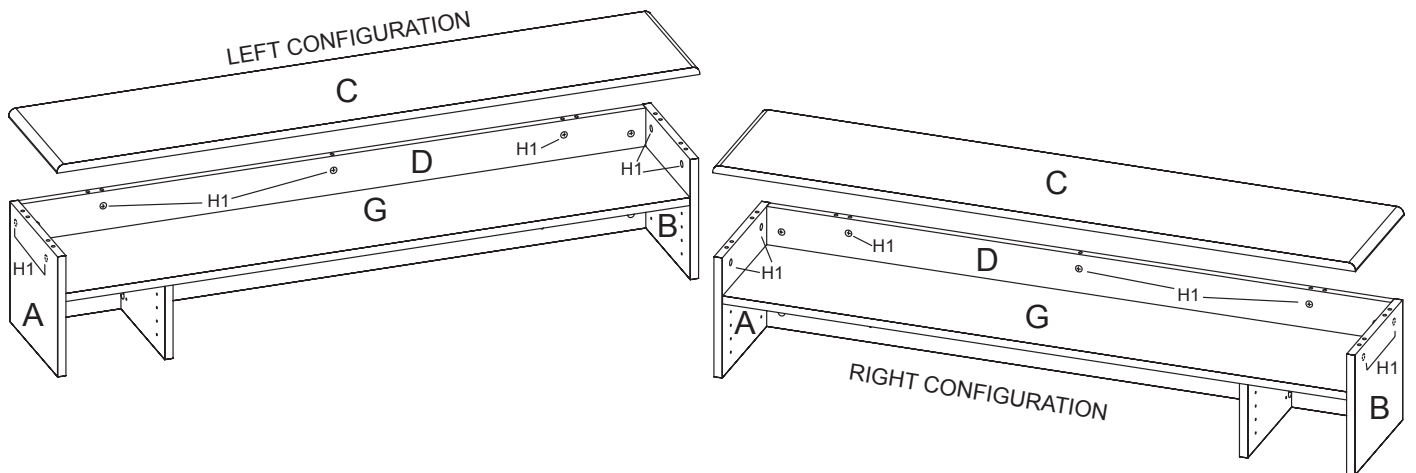
**#10**

LEFT CONFIGURATION

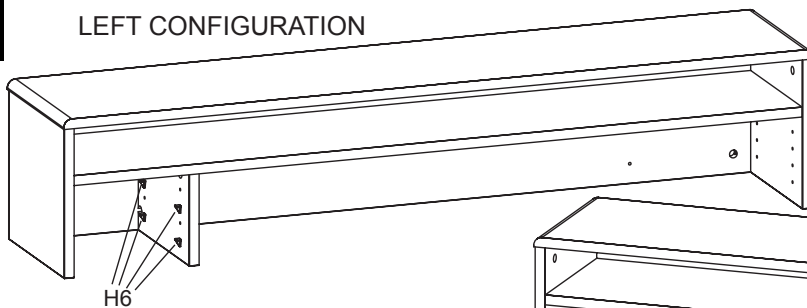

Insert Shelf Support Pins (H6) into Side (A or B) and Partition (E) as shown.

RIGHT CONFIGURATION

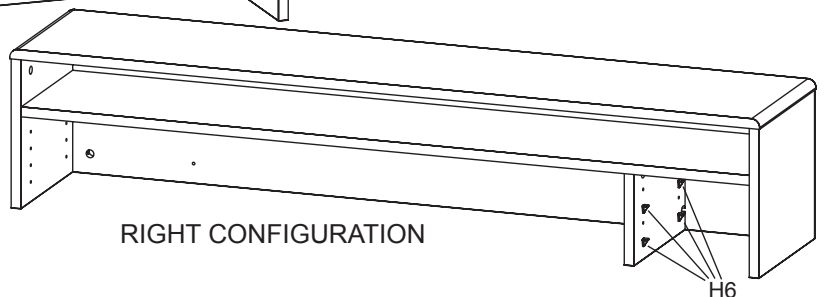

#11

LEFT CONFIGURATION

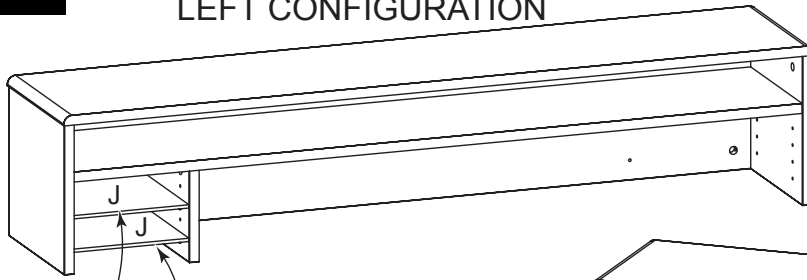

Set the 2 adjustable Shelves (J) onto the Shelf Support Pins. Press the Plastic Label Holders (H7) onto each of the Adjustable Shelves.

RIGHT CONFIGURATION

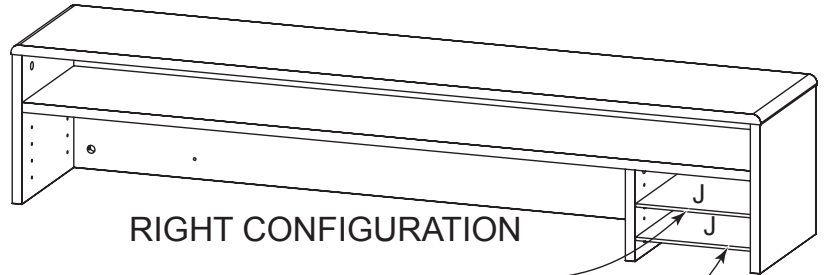

H7



#12

Slide the 5 Shelf Dividers (H8) onto the Fixed Shelf (G) positioning as desired.

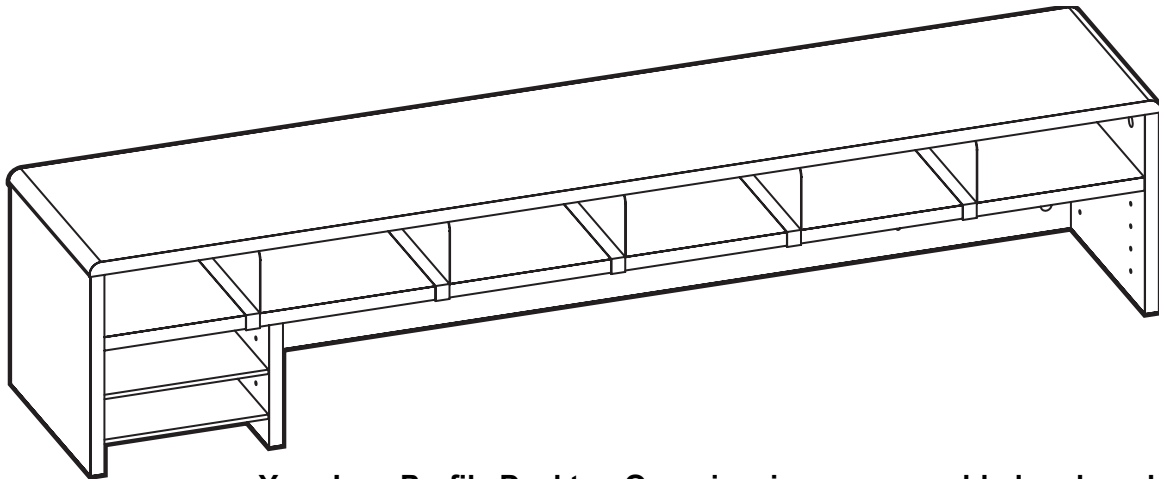

Your Low Profile Desktop Organizer is now assembled and ready to use.