

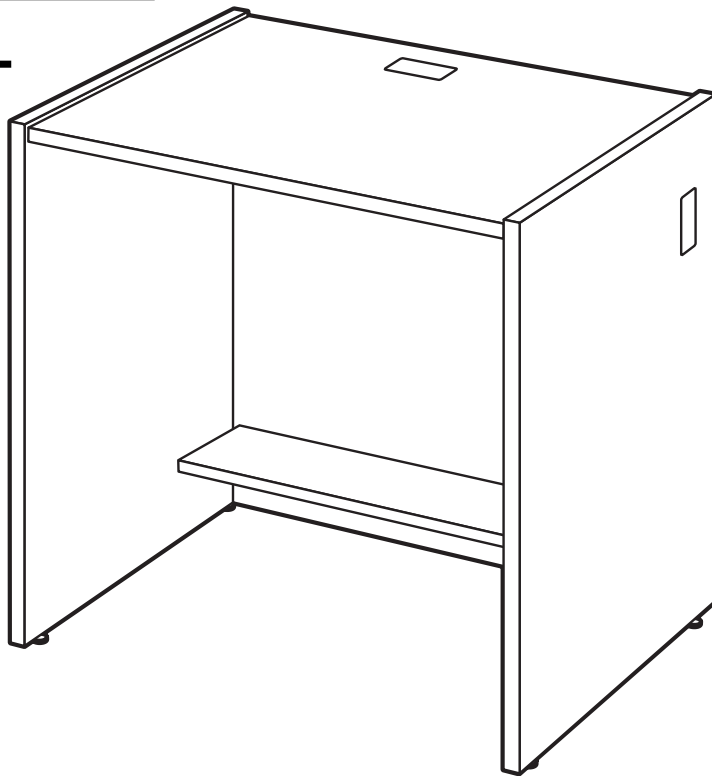

BY  **IRONWOOD**

CIRCULATION DESK
CD3629 / CD3632
CD3639
DESK SHELL



IMPORTANT!

Assembly may require the assistance of another person.

Before you begin assembly:

READ THE DIRECTIONS all the way through one time. This will speed up the process and help you understand the sequence of steps.

COUNT THE PARTS AND HARDWARE before assembly. This ensures you have received all necessary parts before you begin.

TOOLS: You will need a Phillips head screwdriver, a medium slotted screwdriver and a plastic mallet. To protect your new furniture from damage during assembly, it is recommended to work on a carpeted surface.

In the event any parts are missing from this package, send your name, address, telephone number, and a description of the missing part(s) to: **PARTS, Box 1420, Missoula, MT 59806** or call: **1-800-769-5693** or **FAX 1-800-445-5281**.

CAUTION: On assemblies requiring glue, make sure the unit is assembled correctly before gluing. Once this unit is assembled with glue, the manufacturer will not be responsible for damaged parts. Keep a damp cloth or sponge handy to wipe off excess glue.

To care for this furniture, simply wipe with a cloth dampened with glass cleaner containing ammonia-D.

PARTS DIAGRAM

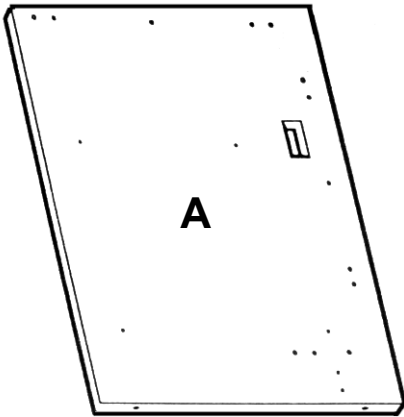

Left Side – CD3629	01011941	1 ea.
Left Side – CD3632	01012041	1 ea.
Left Side – CD3639	01012141	1 ea.

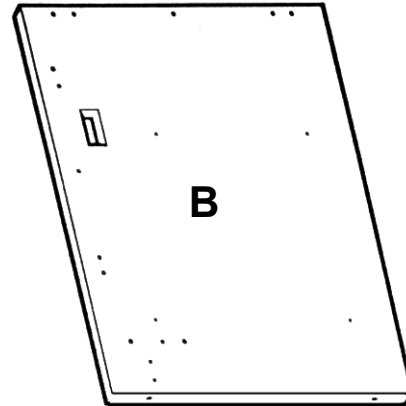

Right Side – CD3629	01011941	1 ea.
Right Side – CD3632	01012041	1 ea.
Right Side – CD3639	01012141	1 ea.

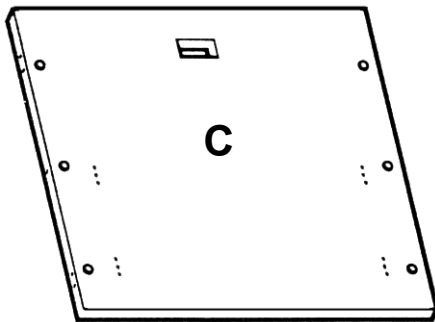

Top	01011901	1 ea.
-----	----------	-------

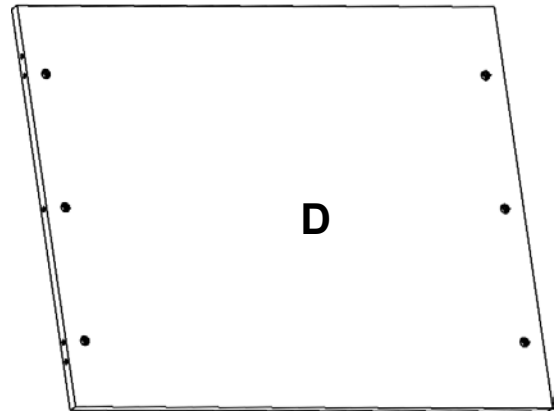

Back – CD3629	01011952	1 ea.
Back – CD3632	01012052	1 ea.
Back – CD3639	01012152	1 ea.

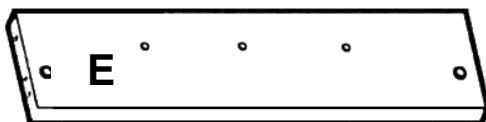

Bottom	01010511	1 ea.
--------	----------	-------

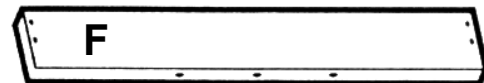

Toeboard	01010172	1 ea.
----------	----------	-------

HARDWARE



H1	Minifix Cam	909810	14 ea.
----	-------------	--------	--------



H2	Leveler Insert	274650	4 ea.
----	----------------	--------	-------

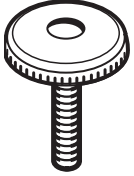

H3	Leveler	300870	4 ea.
----	---------	--------	-------



H4	Minifix Bolt	909834	14 ea.
----	--------------	--------	--------



H5	Wood Dowel	195000	12 ea.
----	------------	--------	--------

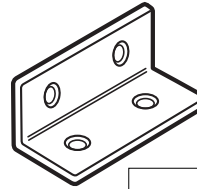

H6	Angle Bracket	401172	2 ea.
----	---------------	--------	-------



H7	#14 x 1/2" Panhead Screw	901233	8 ea.
----	-----------------------------	--------	-------



H8	Confirmat Screw	950100	3 ea.
----	-----------------	--------	-------

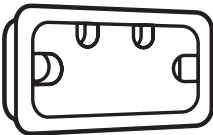

H9	Grommet	286580	3 ea.
----	---------	--------	-------



H10	Connector Sleeve	950200	4 ea.
-----	------------------	--------	-------



H11	Connector Screw	901350	4 ea.
-----	-----------------	--------	-------



H12	Wire Trough	412990	1 ea.
-----	-------------	--------	-------



H13	Panhead Screw	901216	2 ea.
-----	---------------	--------	-------

Using the Minifix System:

Insert the Minifix Cams into the appropriate holes with the arrow facing outwards as shown.

When screwing post into hole, **Do Not** over tighten. Screw post down until bottom face of post flange just touches board surface.

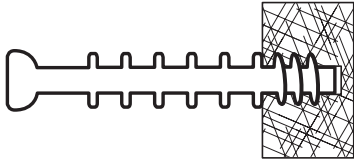

Using the #2 Phillips screwdriver, rotate the Cam Devices a half turn clockwise until snug.

To disassemble, turn the Cam Devices counter-clockwise and remove panels.

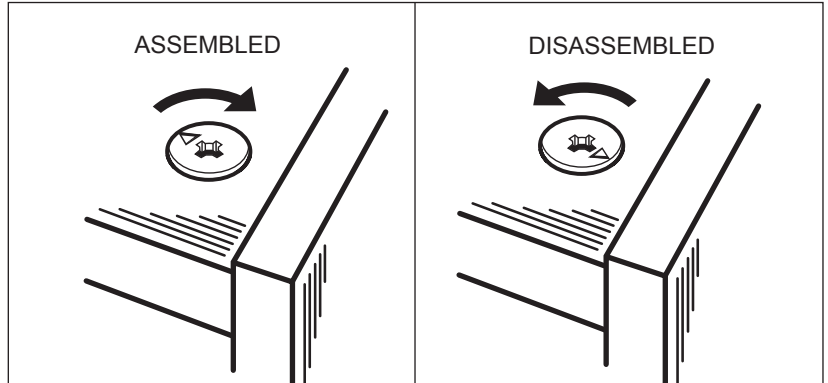
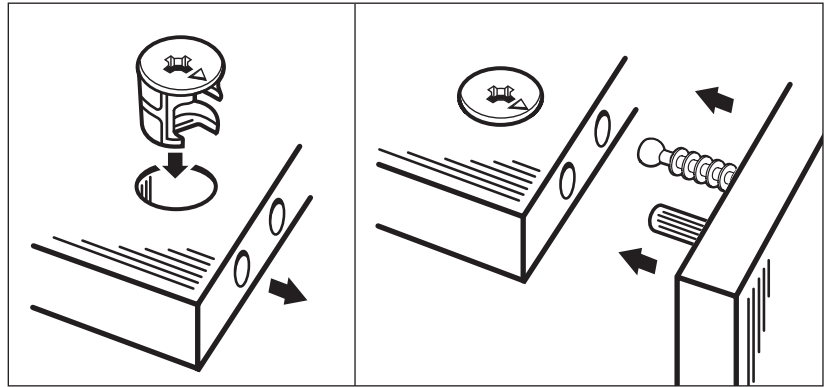

#1

Place the Top (C) and Back (D) onto a clean, carpeted surface with the pre-drilled holes facing up. Insert six Minifix Cams (H1) into each panel with the arrows of the cams facing out.

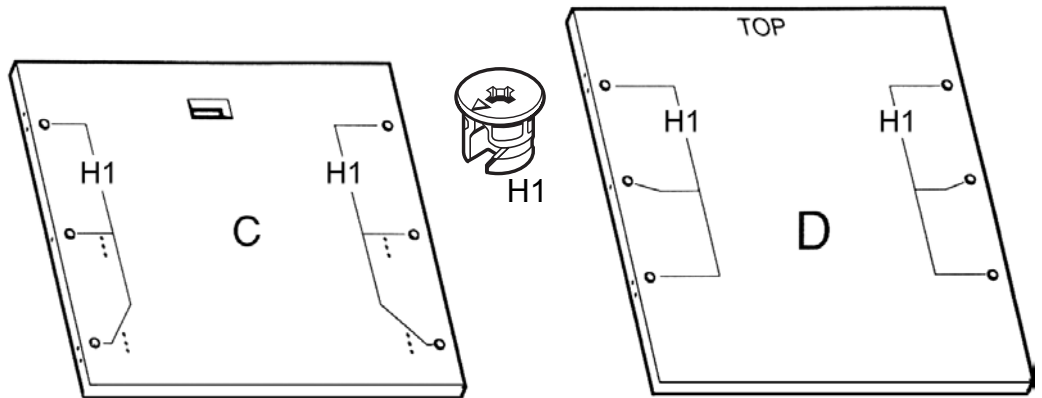

#2

Insert the Leveler Inserts (H2) into the holes in the bottom edges of Left Side (A) and Right Side (B). Using a plastic mallet, tap until flush with the surface. Screw the Levelers (H3) into the Leveler Inserts. Adjust Levelers when the assembled unit is in place.

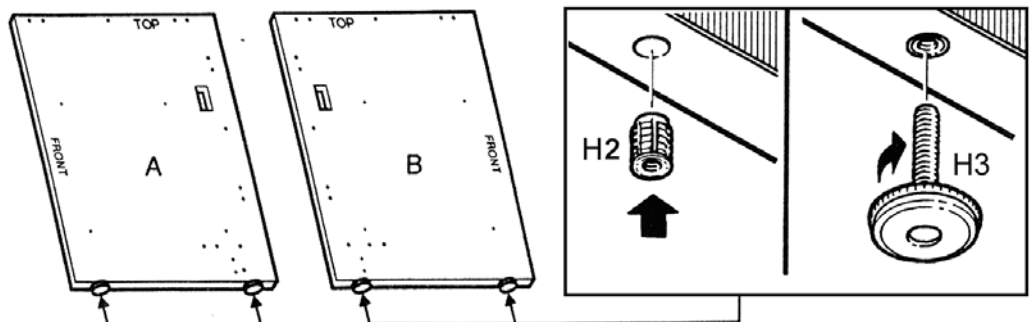

#3

Screw seven Minifix Bolts (H4) into the Sides (A & B) where indicated.

Insert six Dowels (H5) into the Sides where indicated.

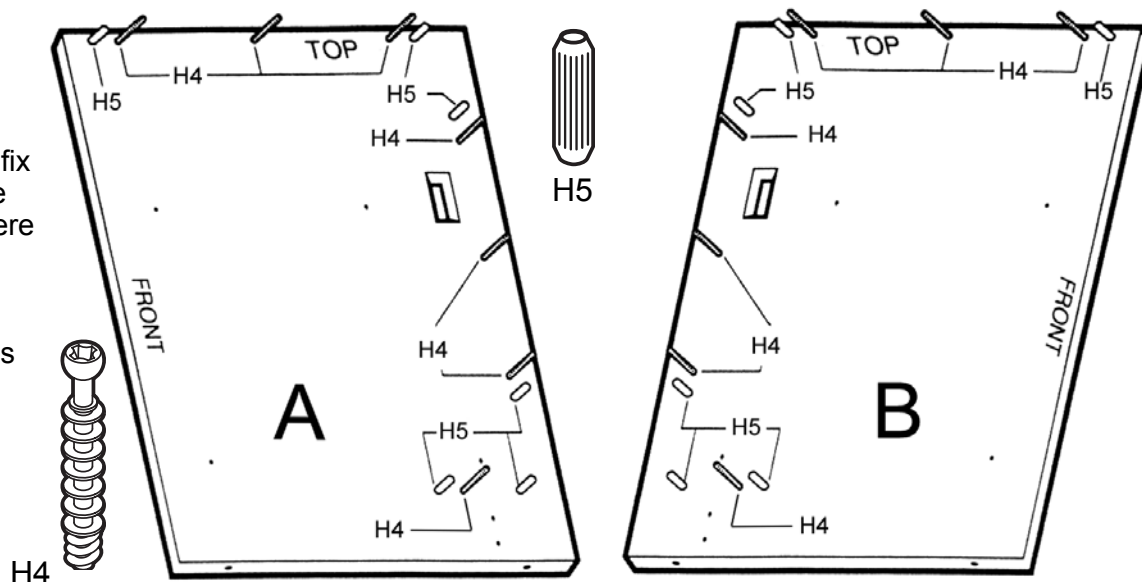

#4

Secure an Angle Bracket (H6) to each end of the Toeboard (F) using the 1/2" Panhead Screws (H7).

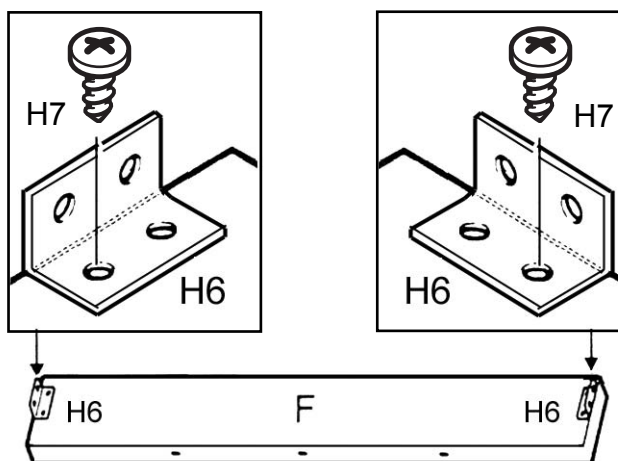

#5

Attach the Toeboard (F) to the Bottom (E) using three Confirmat Screws (H8) through the pre-drilled holes as shown.

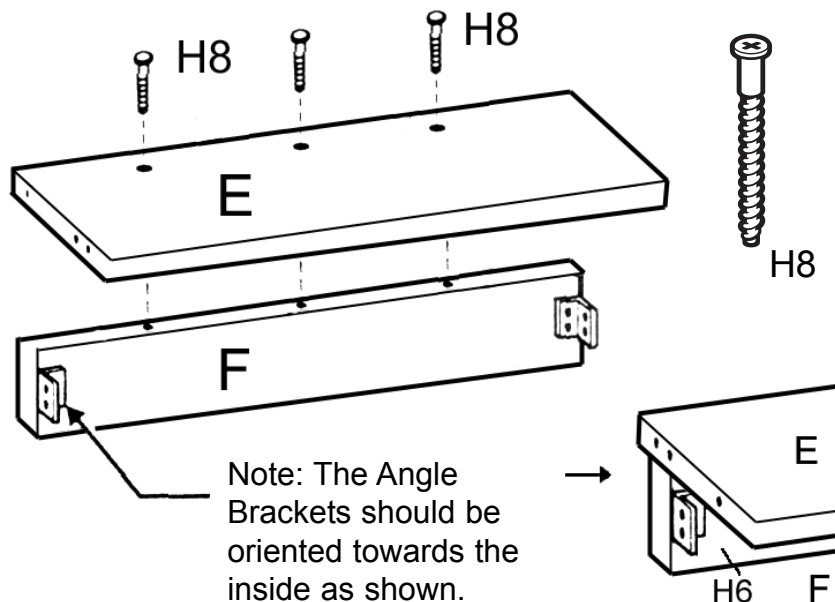

#6

Insert two Minifix Cams (H1) into the Bottom (E) with the arrows of the cams facing out.

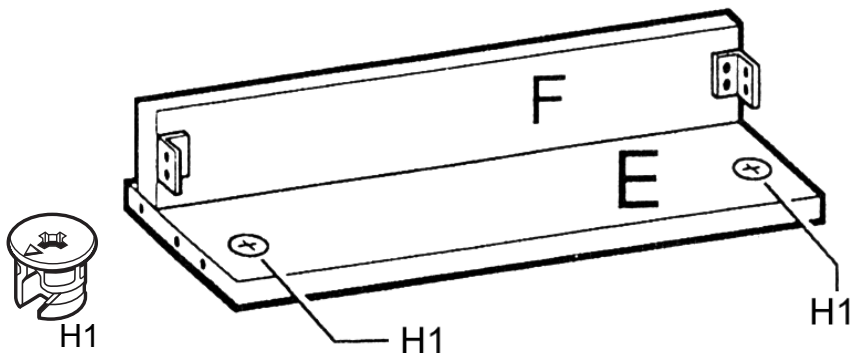

#7

Place the Left Side (A) with the bolts and dowels facing up as shown. Position the Top (C) onto the Left Side and turn cams (H1) clockwise to secure.

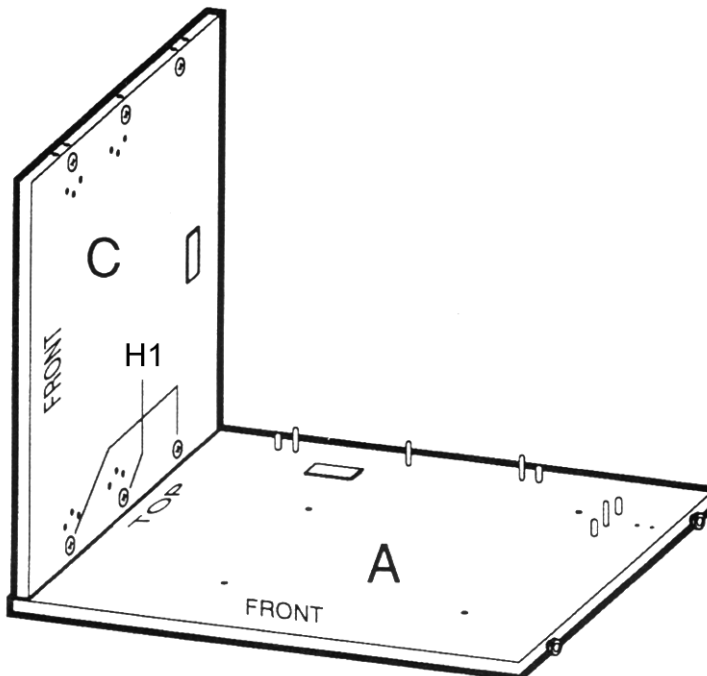

#8

Position the Back (D) onto the Left Side (A) and turn the cams (H1) clockwise to secure.

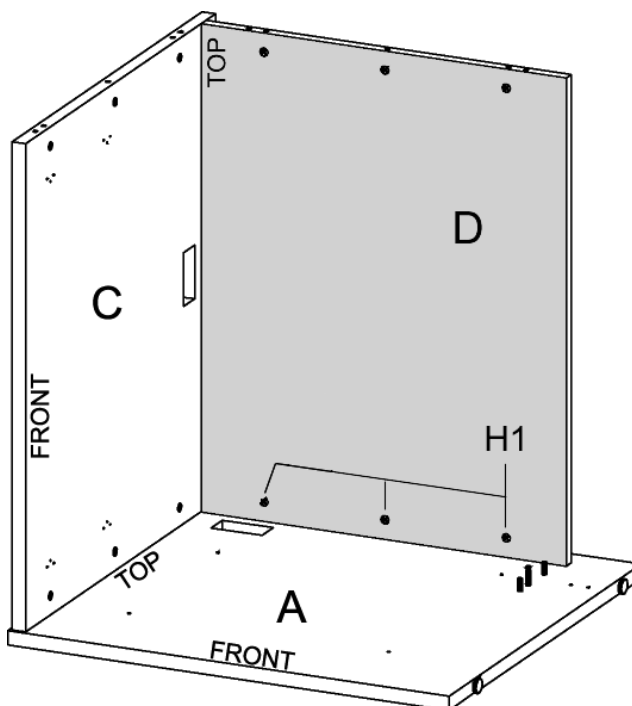

#9

Position the Bottom (E) and Toeboard (F) assembly onto the Left Side (A) and turn cam (H1) clockwise to secure.

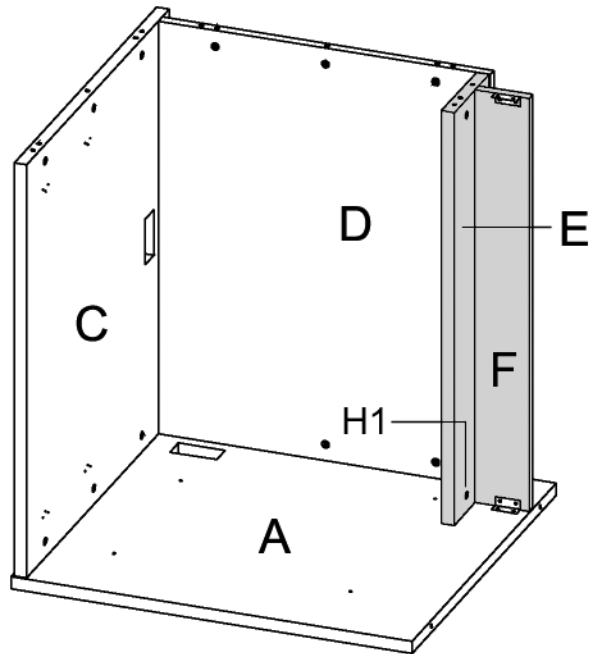

#10

Position the bolts and dowels of the Right Side (B) onto the unit and turn the cams (H1) clockwise to lock in place.

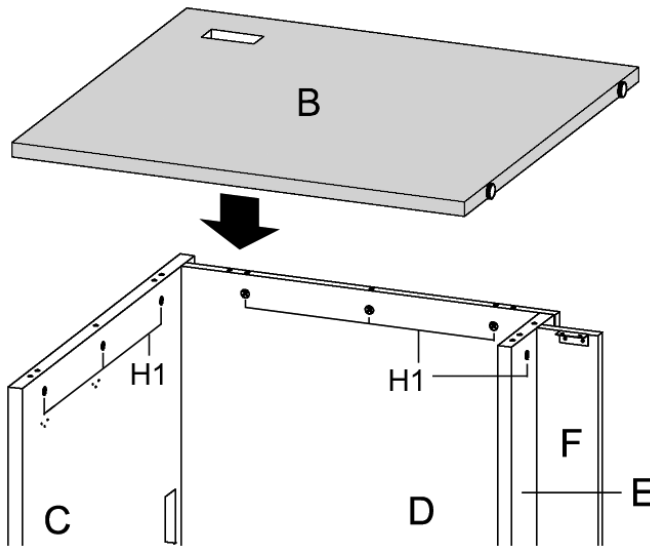

#11

Secure the Angle Brackets (H6) of the Toeboard (F) to each Side (A & B) using 1/2" Panhead Screws (H7).

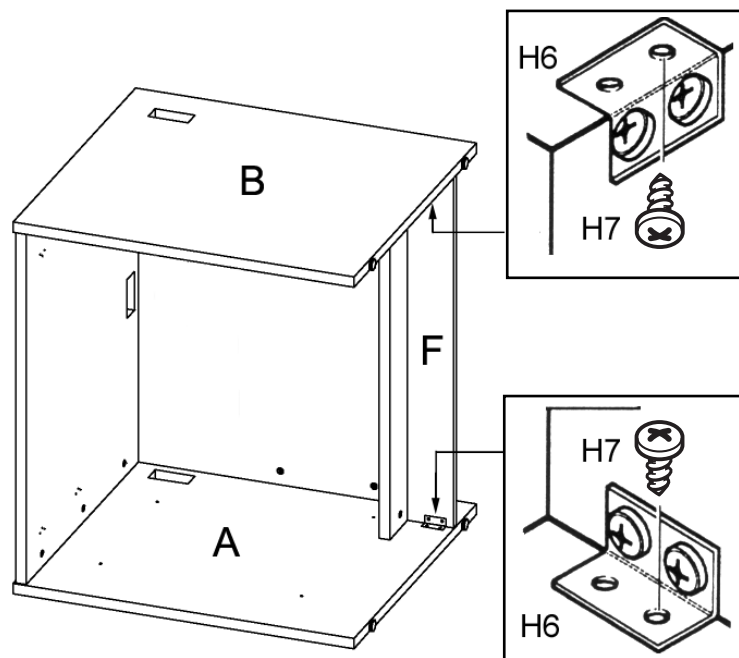

#12

Peel the paper backing from the adhesive strip on the Wire Trough (H12). Attach the Wire Trough to the Back of the unit and secure in place by driving two Panhead Screws (H13) through the predrilled holes in the Wire Trough.

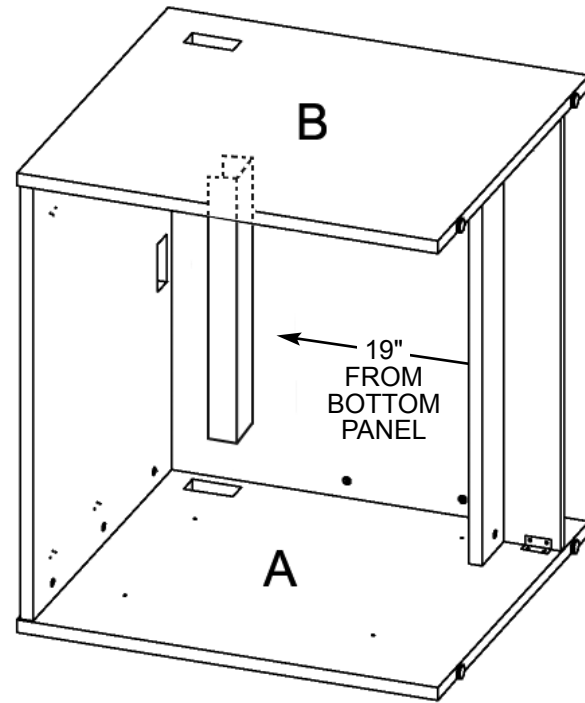
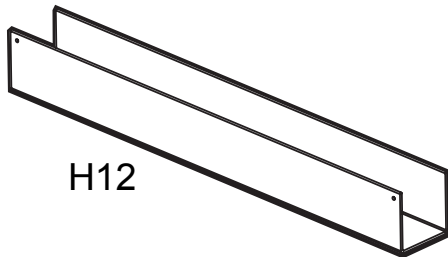

#13

With the assistance of another person, turn the unit upright. Insert Grommets (H9) into the Left Side (A), Right Side (B), and Top (C).

Your Glacier Desk Shell is now fully assembled and ready for use.

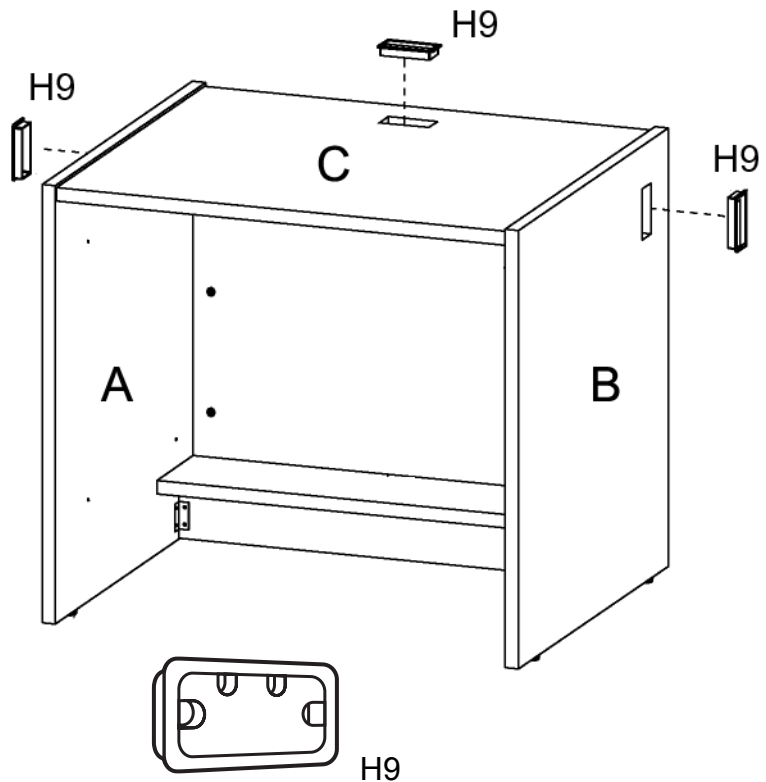

ADJOINING TO OTHER WORKSTATIONS:

Remove Grommets from the panels to be connected.

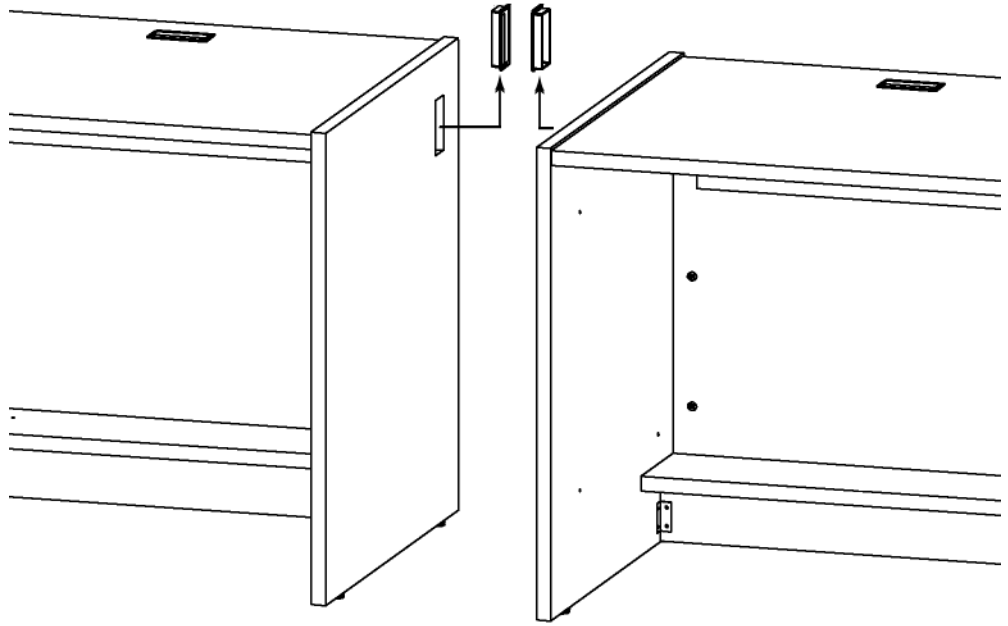

Using a 13/64" bit, drill through the four pilot holes on the inside of each side panel.

Align the side panels of the units to be connected. Tap four Connector Sleeves (H10) through the holes in one side panel and into the holes of the unit to be connected. From the other side, secure the units together using four Connector Screws (H11).

