



BY  **IRONWOOD**

CIRCULATION DESK

CD36R

RISER UNIT

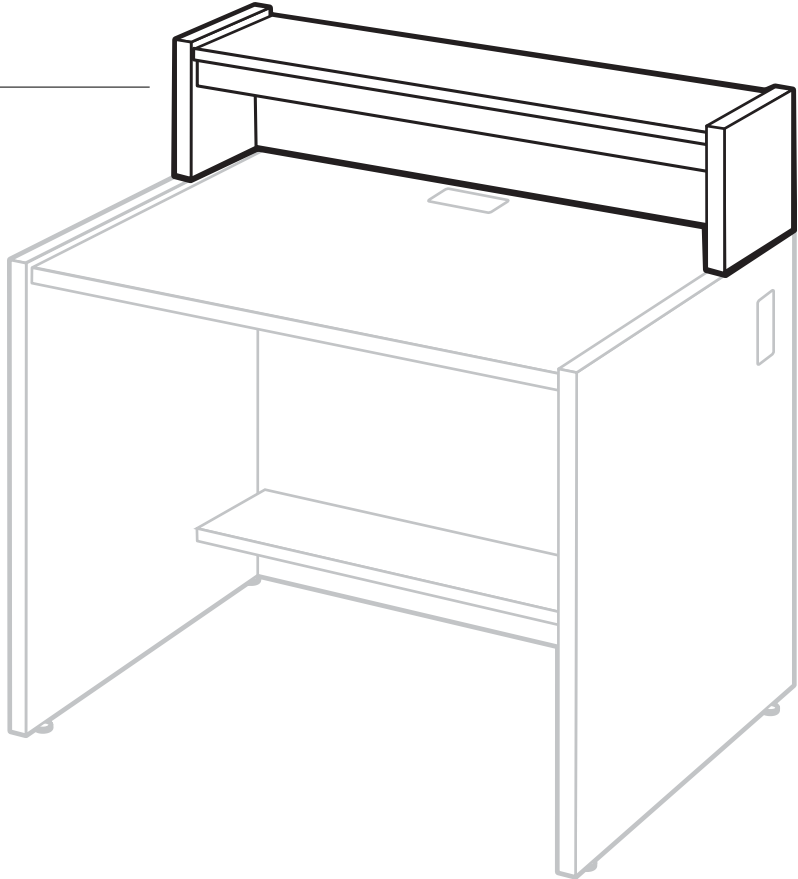

IMPORTANT!

Assembly may require the assistance of another person.

Before you begin assembly:

READ THE DIRECTIONS all the way through one time. This will speed up the process and help you understand the sequence of steps.

COUNT THE PARTS AND HARDWARE before assembly. This ensures you have received all necessary parts before you begin.

TOOLS: You may need a Phillips head screwdriver, a medium slotted screwdriver or a plastic mallet. To protect your new furniture from damage during assembly, it is recommended to work on a carpeted surface.

In the event any parts are missing from this package, send your name, address, telephone number, and a description of the missing part(s) to: **PARTS, Box 1420, Missoula, MT 59806** or call: **1-800-769-5693** or **FAX 1-800-445-5281**.

CAUTION: On assemblies requiring glue, make sure the unit is assembled correctly before gluing. Once this unit is assembled with glue, the manufacturer will not be responsible for damaged parts. Keep a damp cloth or sponge handy to wipe off excess glue.

To care for this furniture, simply wipe with a cloth dampened with glass cleaner containing ammonia-D.

PARTS DIAGRAM

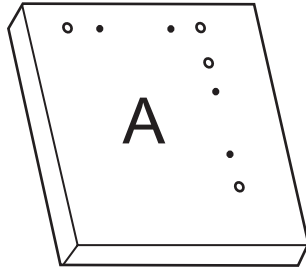

Left Side	01011641	1 ea.
-----------	----------	-------

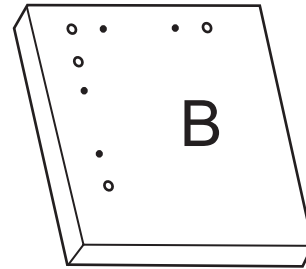

Right Side	01011641	1 ea.
------------	----------	-------

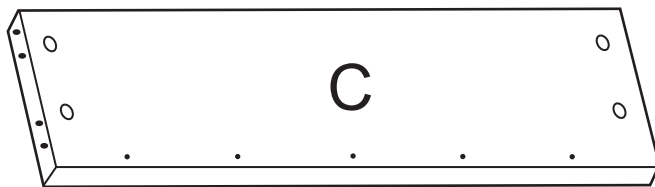

Top	01011601	1 ea.
-----	----------	-------



Back	01011652	1 ea.
------	----------	-------

E

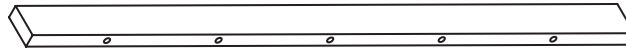

Facia Strip	01011686	1 ea.
-------------	----------	-------

HARDWARE



H1	Minifix Cam	909810	8 ea.
----	-------------	--------	-------



H2	Wood Dowel	195000	13 ea.
----	------------	--------	--------



H3	Glue	295020	1 ea.
----	------	--------	-------



H4	Minifix Bolt	909834	8 ea.
----	--------------	--------	-------

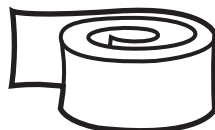

H5	Attachment Tape	298530	2 ea.
----	-----------------	--------	-------

Using the Minifix System:

Insert the Minifix Cams into the appropriate holes with the arrow facing outwards as shown.

When screwing post into hole, **Do Not** over tighten. Screw post down until bottom face of post flange just touches board surface.

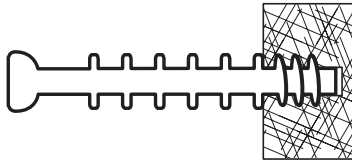

Using the #2 Phillips screwdriver, rotate the Cam Devices a half turn clockwise until snug.

To disassemble, turn the Cam Devices counter-clockwise and remove panels.

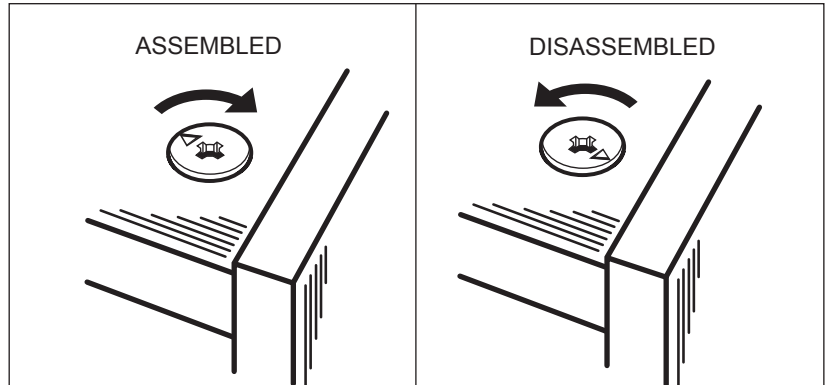
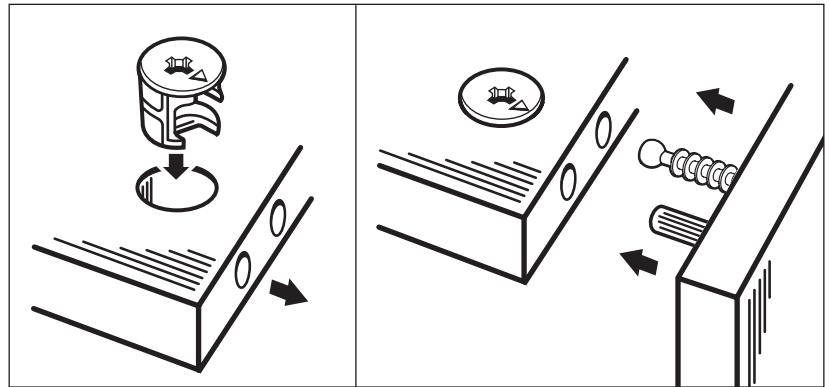

#1

Insert four Minifix Cams (H1) into the Top (C) and Back (D) with the arrows of the cams facing out.

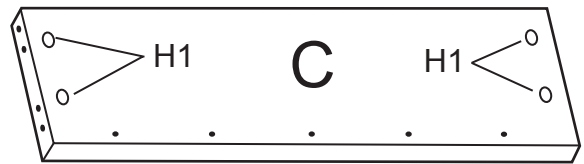

#2

Insert five Wood Dowels (H2) into the Facia Strip (E) by tapping lightly into place with a mallet or hammer.

Apply a small amount of Glue (H3) onto the dowels of the Facia Strip.

Position the Facia Strip dowels into the corresponding holes in the Top (C) and press firmly into place. Wipe away any excess glue with a damp cloth.

Set aside to dry.

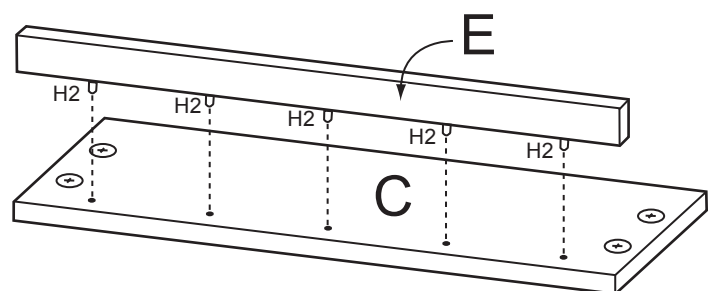
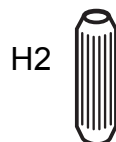

#3

Screw four Minifix Bolts (H4) and insert four Wood Dowels (H2) into the Left Side (A) and Right Side (B) where indicated.

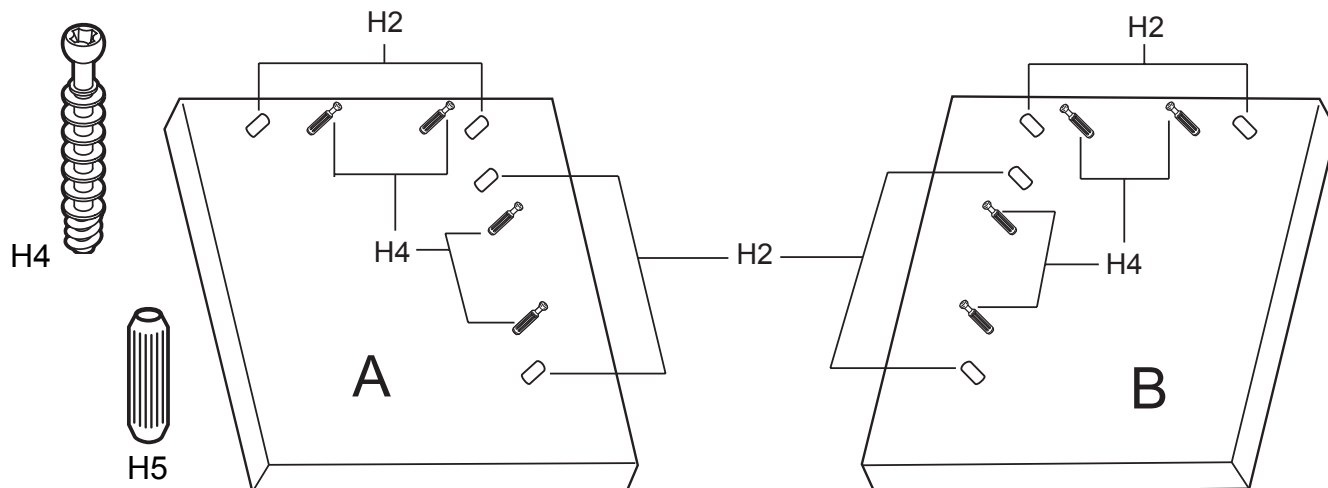
**#4**

Place the Top (C) and Facia Strip (E) on some packing material as shown. Position the bolts and dowels of the Left Side (A) into the Top (C) and turn cams clockwise to secure.

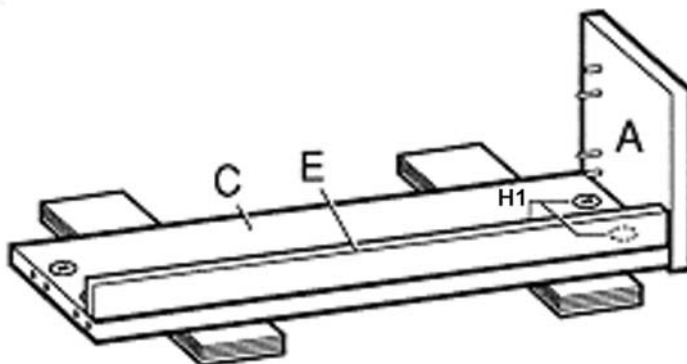
**#5**

Position the Back (D) onto the bolts and dowels of the Left Side (A) and turn the cams (H1) clockwise to secure.

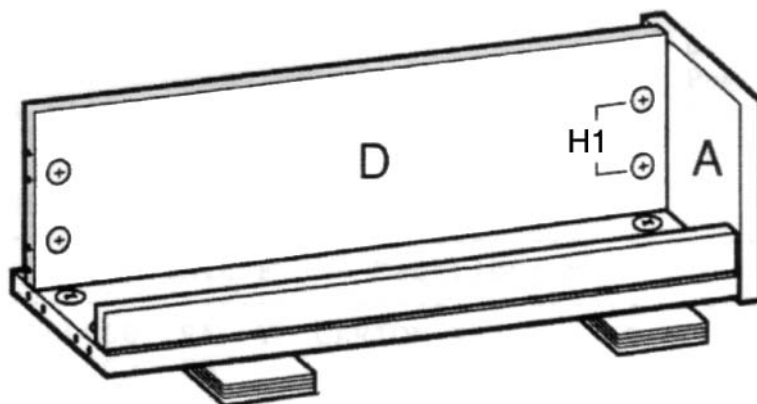
**#6**

Position the Right Side (B) onto the unit and turn the cams (H1) clockwise to secure.

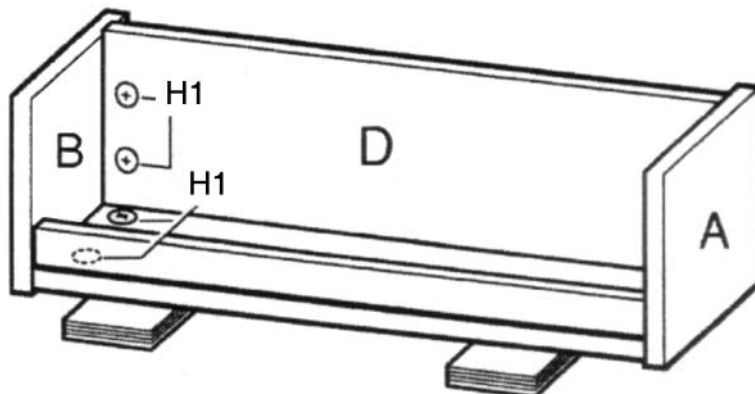

#7

Uncoil the Tape Strips (H5) and affix one strip onto each of the bottom edges of the Left Side (A) and Right Side (B).

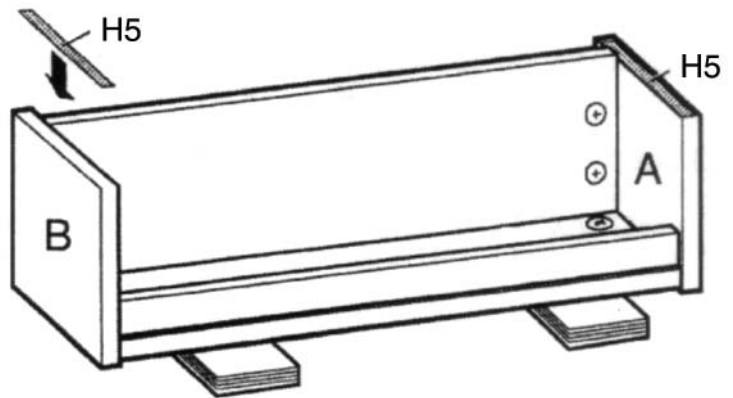

#8

Remove the backing from each Tape Strip (H5) and carefully align rear and side edges of the Riser and the unit to be attached as shown. When aligned, place the Riser on the desk unit.

Note: It will be difficult to remove or reposition the units once joined.

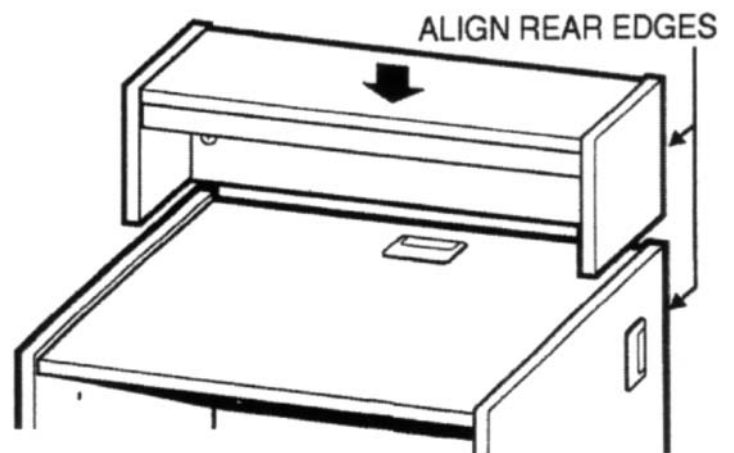

#9

Your Glacier Riser is now fully installed to the Desk Unit and is ready for use.

