



IRONWOOD
MANUFACTURING

GLACIER
LIBRARY FURNITURE

CDHD32-39

Hinged Door Unit

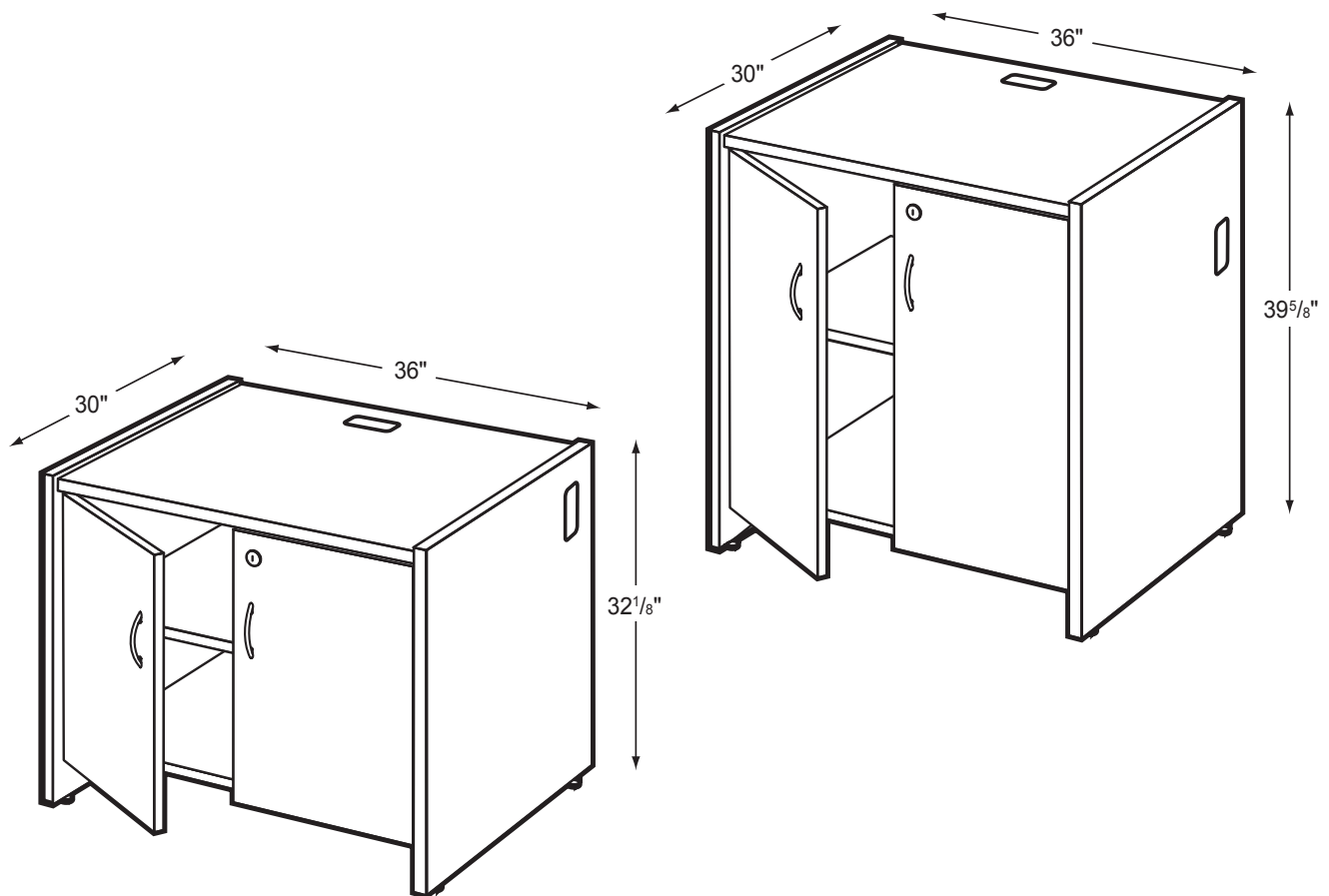

Product Specs

- 1" thermal fused laminate sides, shelves, bottom and top
- 3/4" thermal fused laminate modesty and kick
- Cam and post construction
- Matched edge banding
- Adjustable shelf on 1-1/4" increments
- Five - 2"x 4" grommets with covers
- Locking doors with concealed hinge
- Adjustable leveling glides

0208

Ironwood Manufacturing • P.O. Box 1420 • Missoula, Montana 59806
(406) 721-4747 • (800) 769-5693 • fax (406) 721-8424 • www.ironwoodmfg.com