



BY  IRONWOOD

LIBRARY SHELVING UNIT

**LS42SB LS48SB
LS60SB LS72SB
LS84SB**

**SINGLE
BASE UNIT**



IMPORTANT!

Assembly may require the assistance of another person.

Before you begin assembly:

READ THE DIRECTIONS all the way through one time. This will speed up the process and help you understand the sequence of steps.

COUNT THE PARTS AND HARDWARE before assembly. This ensures you have received all necessary parts before you begin.

TOOLS: You may need a Phillips head screwdriver, a medium slotted screwdriver or a plastic mallet. To protect your new furniture from damage during assembly, it is recommended to work on a carpeted surface.

In the event any parts are missing from this package, send your name, address, telephone number, and a description of the missing part(s) to: PARTS, Box 1420, Missoula, MT 59806 or call: 1-800-769-5693 or FAX 1-800-445-5281.

CAUTION: On assemblies requiring glue, make sure the unit is assembled correctly before gluing. Once this unit is assembled with glue, the manufacturer will not be responsible for damaged parts. Keep a damp cloth or sponge handy to wipe off excess glue.

To care for this furniture, simply wipe with a cloth dampened with glass cleaner containing ammonia-D.

PARTS DIAGRAM

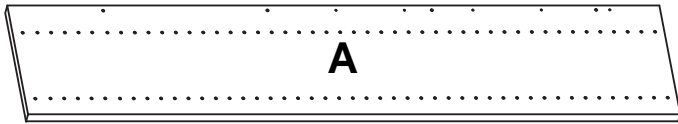

Left Side - LS42SB	01200141	1 ea.
Left Side - LS48SB	01200241	1 ea.
Left Side - LS60SB	01200341	1 ea.
Left Side - LS72SB	01200441	1 ea.
Left Side - LS84SB	01200541	1 ea.

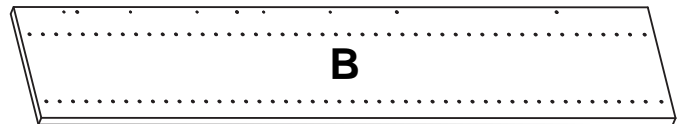

Right Side - LS42SB	01200141	1 ea.
Right Side - LS48SB	01200241	1 ea.
Right Side - LS60SB	01200341	1 ea.
Right Side - LS72SB	01200441	1 ea.
Right Side - LS84SB	01200541	1 ea.

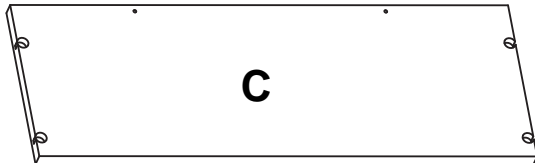

Top	01200101	1 ea.
-----	----------	-------



Fixed/ Adjustable Shelf	LS42SB	01200124	3 ea.
	LS48SB		3 ea.
	LS60SB		4 ea.
	LS72SB		5 ea.
	LS84SB		6 ea.

HARDWARE



H1	Tab-V Plastic Housing	909930	LS42SB - 16 ea. LS48SB - 16 ea. LS60SB - 20 ea. LS72SB - 24 ea. LS84SB - 28 ea.
----	-----------------------------	--------	---



H2	Book Stop	412226	LS42SB - 3 ea. LS48SB - 3 ea. LS60SB - 4 ea. LS72SB - 5 ea. LS84SB - 6 ea.
----	-----------	--------	--



H3	# 8 x 5/8" Panhead Screw	988056	LS42SB - 25 ea. LS48SB - 25 ea. LS60SB - 30 ea. LS72SB - 35 ea. LS84SB - 40 ea.
----	--------------------------------	--------	---

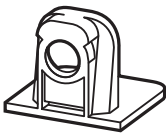

H4	Tab-V Metal Flange	909931	8 ea.
----	-----------------------	--------	-------



H5	Varianta Bolt	988060	8 ea.
----	---------------	--------	-------

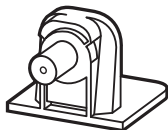

H7	Tab-V Metal Shelf Clip	909932	LS42SB - 8 ea. LS48SB - 8 ea. LS60SB - 12 ea. LS72SB - 16 ea. LS84SB - 20 ea.
----	---------------------------	--------	---

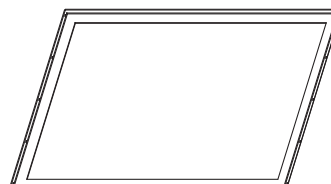

H6	Metal Frame	412026	1 ea.
----	-------------	--------	-------

If you have purchased an Adder unit
to be assembled in conjunction with this Base unit,

it is important to read all the way through the Adder instructions
(enclosed in the Adder carton) before beginning. It will be necessary
to substitute a Divider (J) for a Right Side (B) during assembly.

If you have purchased the Back option or the Toe Space option
to be assembled in conjunction with this Base unit,

it is important to read through the Back option
and/or Toe Space option directions before beginning.

NOTE:

**The diagrams show one size for ease of viewing.
Any differences will be indicated in each step's text.**

USING THE TAB-V SYSTEM:

Using a plastic mallet, tap in the plastic housings with the flat edge facing outwards until flush with the surface.

IMPORTANT! The flat edge of the plastic housing must be aligned with the shelf edge. Plastic Housings cannot be repositioned once installed.

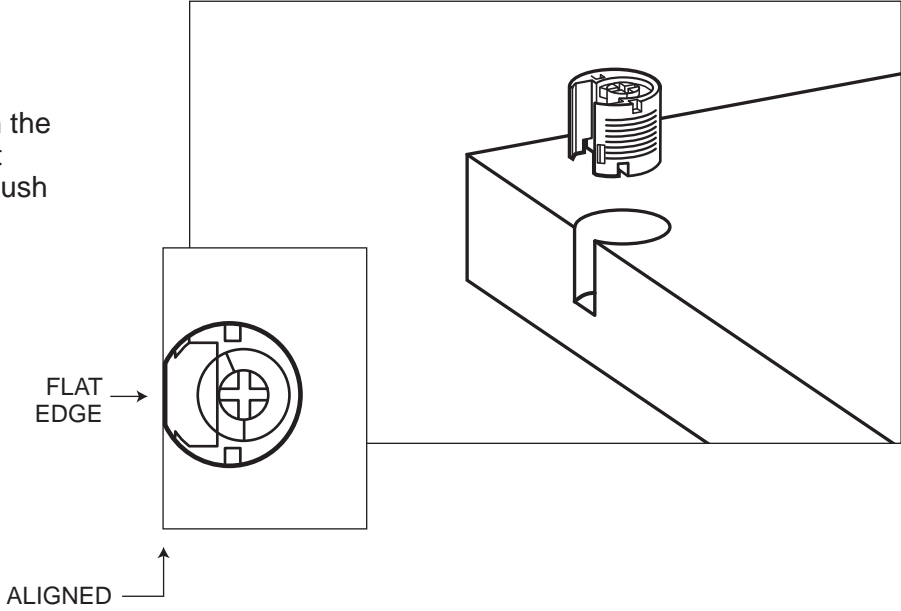

For a Fixed Shelf or Top, install the metal flange using a System (Varianta) Screw as shown. **DO NOT** over tighten!

For an Adjustable Shelf, use the Metal Shelf Clip.

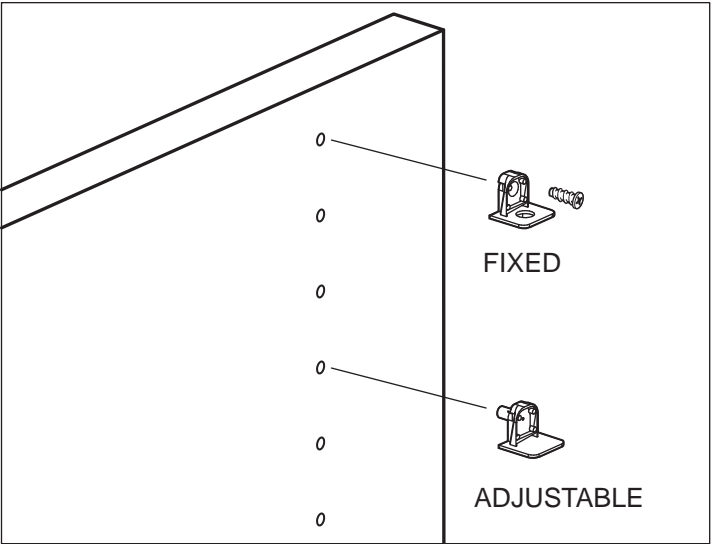

Slide the shelf into place over the Metal Flanges and push down until fully seated.

Turn the rotating portion (Cam) 1/2 turn to lock in place.

To remove, simply turn the Cam counter clockwise 1/2 turn and lift the shelf off of the Metal Flanges.

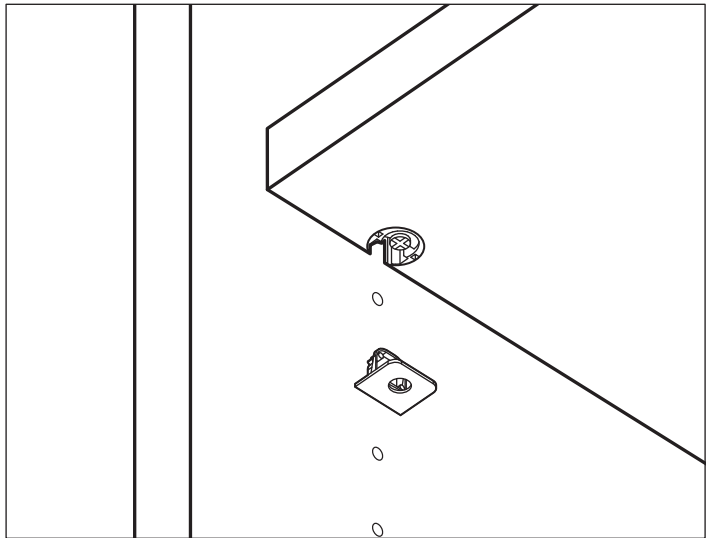

#1

Install four Plastic Housings (H1) into each shelf. Attach a Book Stop (H2) to each Fixed/Adjustable Shelf (E) using five Panhead Screws (H3) in the pre-drilled holes.

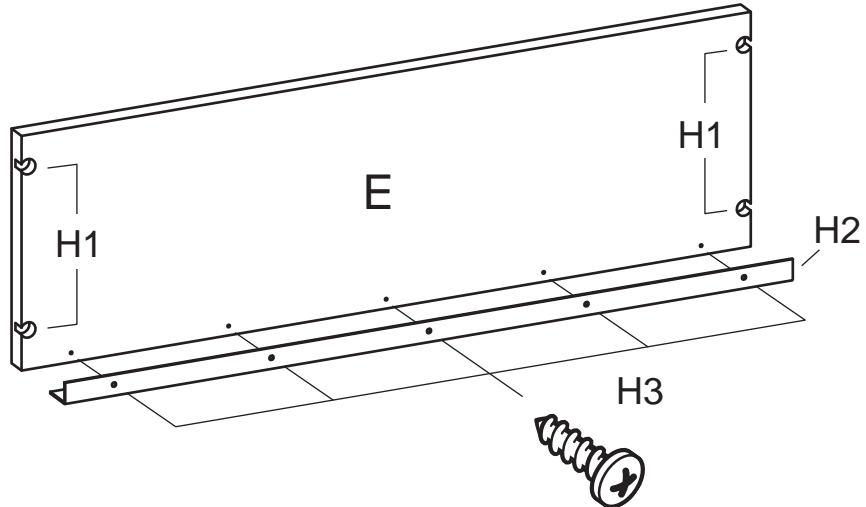

#2

Install four Plastic Housings (H1) into the Top Panel (C) as shown.

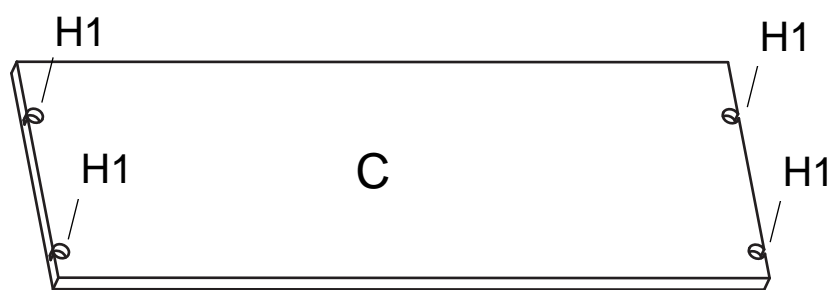

#3

Place both Sides (A & B) on a clean, carpeted surface as shown. Install Metal Flanges (H4) using Varianta Screws (H5) in each Side Panel into the selected pre-drilled holes as indicated.

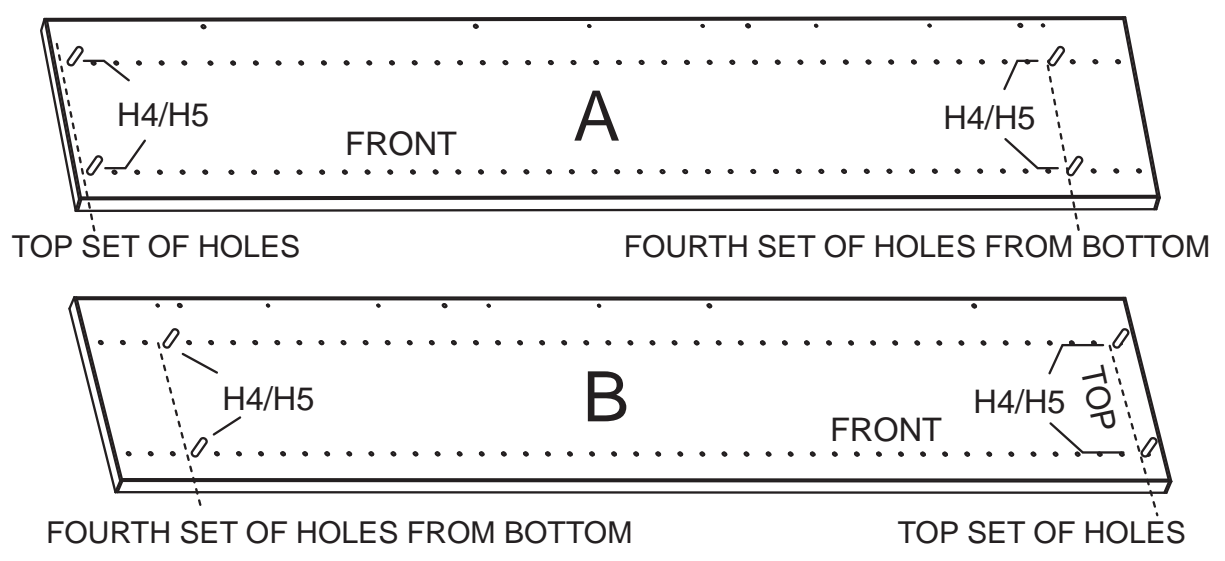
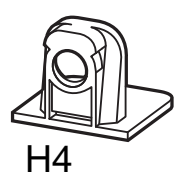

#4

Attach a Metal Frame (H6) or Back Panel (D).

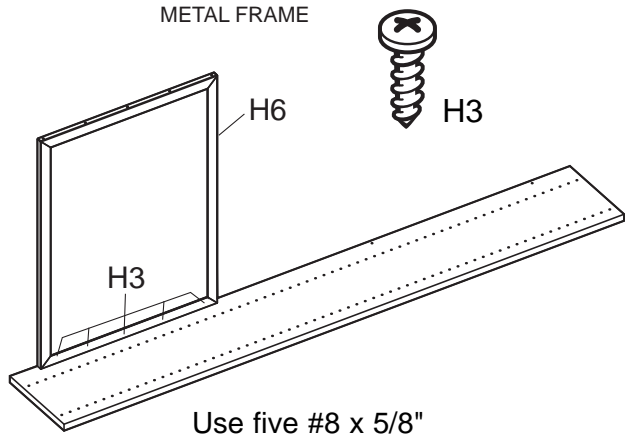

Use five #8 x 5/8" Panhead Screws (H3).

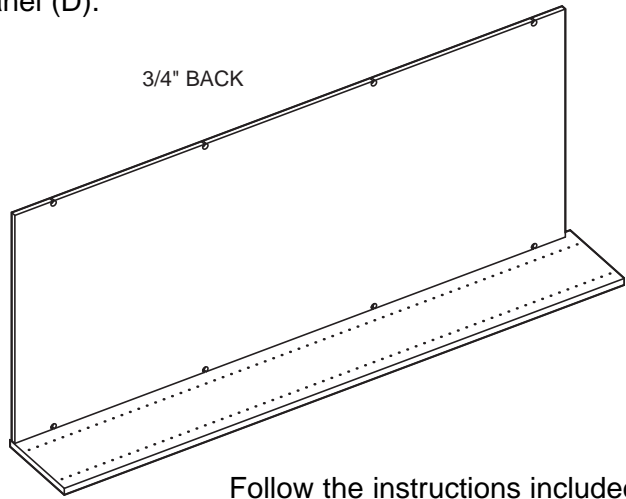

Follow the instructions included with the Back Panel.

NOTE: If you are installing an Adder, follow the instructions for an Adder unit at this time.

#5

With the assistance of another person, stand the assembly upright and install the other side panel (B).

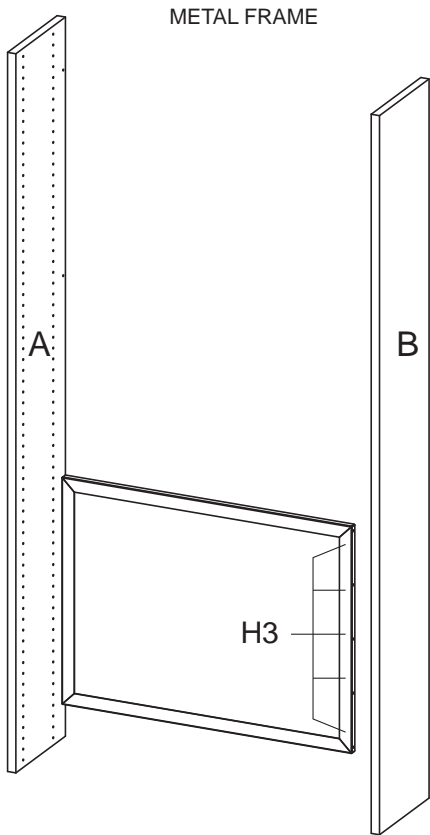

Use five #8 x 5/8" Panhead Screws.

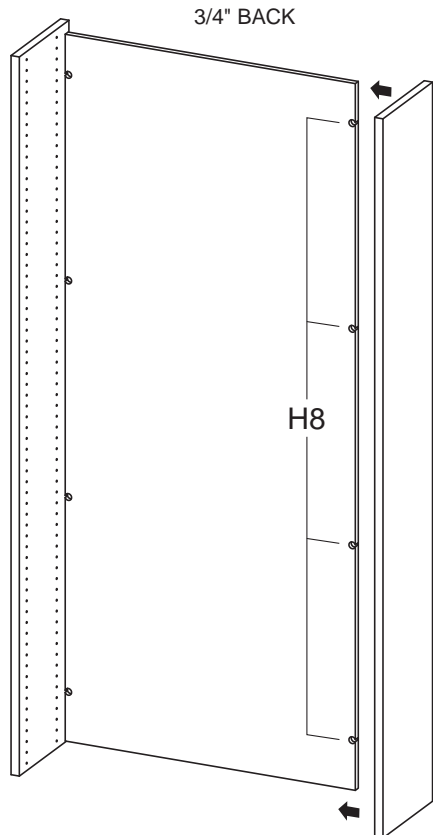

Turn Rafx Cams (H8) 1/2 turn clockwise to tighten.

NOTE: If you are installing the Toe Space option, it is recommended to install the Toe Space at this time. Follow the directions included with the Toe Space option.

#6

Attach the Top Panel (C) and the Fixed Shelf (E) using the Tab-V System. Turn the Cams 1/2 turn to tighten.

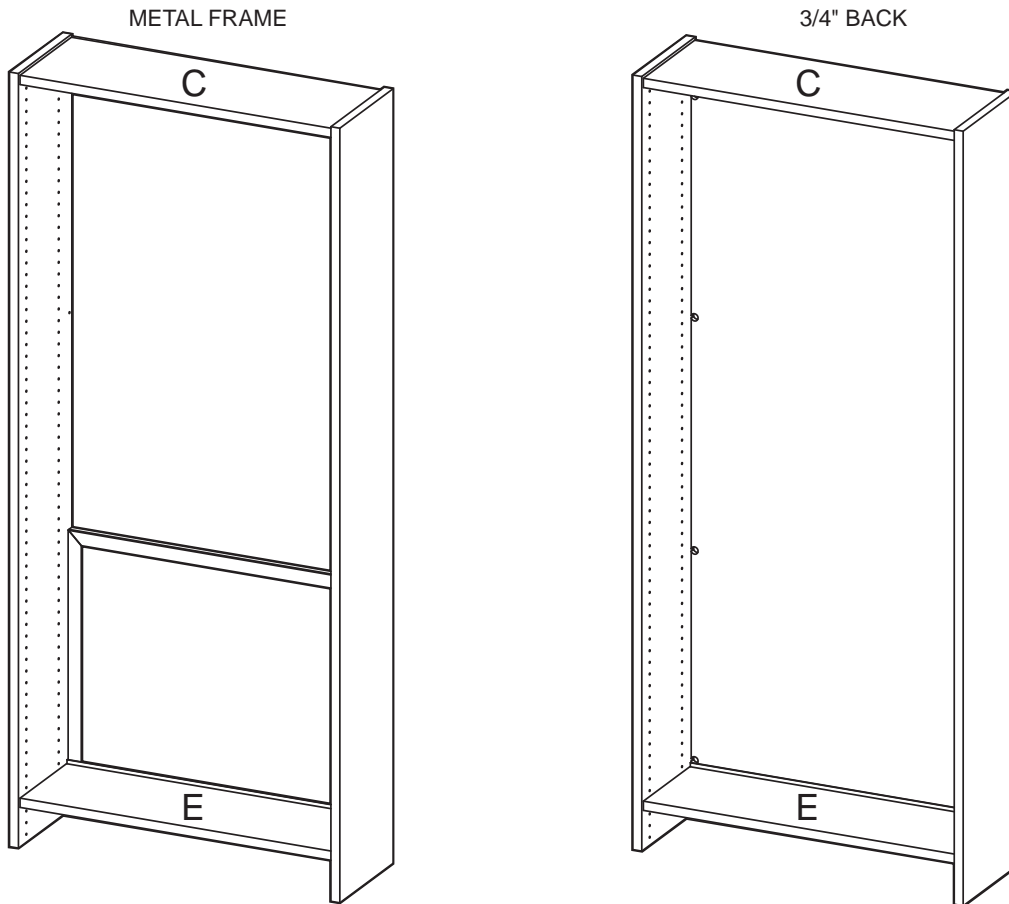

#7

Insert shelf pins (H7) at desired shelf heights. Place the Adjusting Shelves (E) in the unit.

Review the instructions for installing shelves, "Using the Tab-V System" on the 4th page of these instructions.

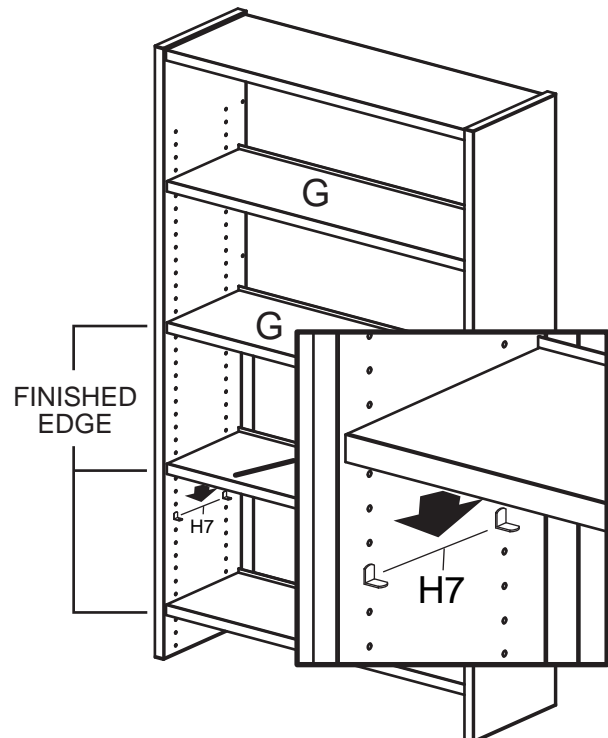

#8

Your Glacier Library Shelving Unit is now assembled and ready for use.

